

Operating Instructions

DS Series Motorized Gate

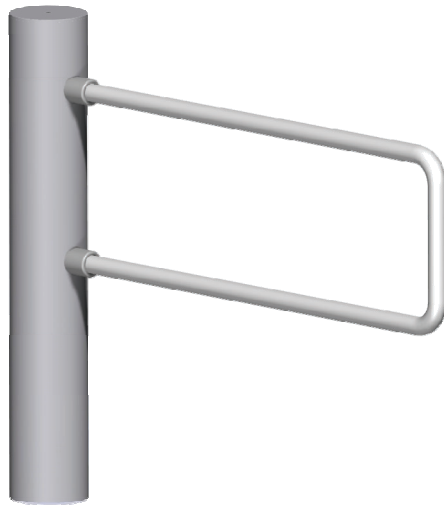

Notes

1	General	7
1.1	Information regarding the operating instructions	7
1.2	Pictogram explanation	8
1.3	Limitation of liability.....	9
1.4	Copyright protection.....	9
1.5	Scope of delivery	10
1.6	Warranty	10
1.7	Customer service.....	11
1.8	Environmental protection.....	11
2	Safety	12
2.1	Intended use	12
2.2	Operator's Responsibility	13
2.3	Changes and modifications	13
2.4	Specialists and operating personnel.....	14
2.4.1	Requirements	14
2.5	Personal protective equipment	15
2.6	Occupational safety and special dangers	15
2.6.1	Danger pictograms on the motorized gates	15
2.6.2	Hazard notes and occupational safety	16
3	Technical data	19
3.1	Dimensions	19
3.1.1	Motorized gate in bracket version	19
3.1.2	Motorized gate in wing version.....	20
3.2	Electrical connection	20
3.3	Operating conditions	21
3.4	Weight.....	21
3.5	Performance data	21
4	Design and function	22
4.1	Design.....	22
4.2	Definition left and right motorized gate.....	23
4.3	Function	23
5	Assembly and installation	24
5.1	Safety.....	24
5.2	Requirements for assembly	26
5.3	Foundation and empty conduits.....	26
5.3.1	Foundation plan.....	27

Contents

- 5.4 Mounting the motorized gate..... 28
 - 5.4.1 Mounting the gate on the foundation 29
 - 5.4.2 Disassemble gate 30
- 6 Electrical connection 33**
 - 6.1 Safety 33
 - 6.2 Connecting the power supply..... 35
 - 6.3 Connect control lines to MBC-111 35
 - 6.3.1 Digital inputs 36
 - 6.3.2 Relay outputs..... 37
- 7 Assemble MPS column..... 38**
 - 7.1 Mounting the locking element 38
 - 7.2 Adjusting the mechanical end stops 39
- 8 Commissioning 40**
 - 8.1 Safety 40
 - 8.2 Initial commissioning 41
 - 8.3 CAN bus addressing and termination 42
 - 8.4 Setting the home position and hold-open time via button..... 43
 - 8.4.1 Setting the home position 43
 - 8.4.2 Set hold-open time..... 44
- 9 Function description 45**
 - 9.1 Power-off state 45
 - 9.2 Start-up routine 45
 - 9.3 Homing 45
 - 9.4 Regular movement process 46
 - 9.5 Special cases within motion sequence 47
 - 9.5.1 Obstacle recognition during the movement..... 47
 - 9.5.2 Turning back during the movement..... 47
 - 9.5.3 Attempted vandalism 48
 - 9.5.4 Emergency..... 48
- 10 Setting gate parameters – "MPS-Diag" 49**
 - 10.1 Driver installation under Windows 7..... 50
 - 10.1.1 Automatic driver installation via setup assistant..... 50
 - 10.1.2 Manual driver installation..... 51
 - 10.1.3 Enter the port number in the program "MPS-Diag"..... 52
 - 10.2 Connect laptop to control device MB-111 53
 - 10.3 Using the MPS-Diag program..... 54

10.4	Function and parameter settings	55
10.4.1	Version left / right	55
10.4.2	Brake activated / not activated	56
10.4.3	Select size of the locking element	57
10.4.4	Select reset source.....	57
10.4.5	Stalled behavior (Behavior when obstruction detected).....	57
10.4.6	Set hold-open time	58
10.4.7	Set speed	58
10.4.8	Heating active while standing.....	58
10.4.9	Teaching the three possible positions	59
10.4.10	Reset all parameters to factory settings.....	61
10.5	Firmware download	62
10.5.1	Firmware download using a ".mcp file"	64
10.5.2	Firmware download using an ".s file"	64
10.6	Download between MBC-111 and MMC-120	66
10.7	Reading errors	67
10.8	Status request.....	68
11	Maintenance	69
11.1	Safety	69
11.2	Cleaning	70
11.3	Maintenance schedule.....	71
12	Malfunctions	72
12.1	Safety	72
12.2	Error codes on the logic controller MBC-111.....	73
13	Spare parts	75
14	Decommissioning and disposal	76
15	Appendix.....	78
15.1	Electric circuit diagram.....	78
Index.....		79



1 General

1.1 Information regarding the operating instructions

These operating instructions provide important information on how to deal with the motorized gate. Prerequisite for safe working is the observance of all specified safety notes and instructions.

In addition, the local accident prevention regulations valid at the barrier's area of application and general safety regulations have to be complied with.

Carefully read the operating instructions before starting any work! They are a product component and must be kept well accessible to the personnel at all times.

When passing the barrier on to third parties, the operating instructions must also be handed over.

Components from other suppliers may have their own safety regulations and instructions for use. These must also be observed.

General

1.2 Pictogram explanation

Warning notes

Warning notes are characterised by pictograms in these operating instructions. The warning notes are followed by signal words expressing the scale of the hazard.

It is absolutely essential to observe the notes and to proceed with caution in order to prevent accidents as well as bodily injuries and property damage.

⚠ DANGER	
	The signal word DANGER points to an immediately dangerous situation, which leads to death or severe injuries if it is not avoided.

⚠ WARNING	
	The signal word WARNING points to a potentially dangerous situation, which can lead to death or severe injuries if it is not avoided.

⚠ CAUTION	
	The signal word CAUTION points to a potentially dangerous situation, which can lead to minor injuries if it is not avoided.

NOTICE	
	The signal word NOTICE points to a potentially harmful situation, which can lead to property damage if it is not avoided.

Hints and recommendations



NOTE!

... highlights useful hints and recommendations as well as information for an efficient and trouble-free operation.

1.3 Limitation of liability

All specifications and notes in these operating instructions were compiled with consideration to the valid standards and regulations, the state of the art as well as to our long-standing knowledge and experience.

The manufacturer is not liable for damage caused by:

- Non-observance of the operating instructions
- Improper use
- Deployment of non-trained personnel
- Arbitrary modifications
- Technical changes
- Use of non-approved spare and wear parts.

The actual scope of supply may differ from the explanations and illustrations described in this manual in case of special designs, if additional order options are made use of, or due to latest technical changes.

1.4 Copyright protection

Surrendering the operating instructions to third parties without written permission of the manufacturer is not permitted.



NOTE!

Content details, texts, drawings, pictures and other illustrations are protected by copyright and are subject to industrial property rights. Any improper use shall be liable to prosecution.

Any type and form of duplication – also of extracts – as well as the exploitation and/or communication of the contents are not permitted without the manufacturer's written declaration of consent.

General

1.5 Scope of delivery

The scope of delivery comprises:

- 1 x Motorized gate with integrated drive and integrated control units MBC and MMC
- 1 x Locking element
- 1 x USB-extension
- 1 x Drilling jig
- 1 x Fastening kit (only within Europe)
- 1 x Software on data carrier

Supplied documentation:

- 1 x Operating instructions
- 1 x Electric circuit diagram

Optionally available:

- MPS-Diagnostic Windows software for setting functions and parameters and for error diagnosis

1.6 Warranty

Units are warranted against defects in materials and workmanship for a period of one year from date of invoice.

1.7 Customer service

Designed Security, Inc.
1402 Hawthorne Street
Bastrop Texas 78602
800-272-3555 option 2 or 512-321-4426 option 2



NOTE!

In order to enable fast handling note the data of the type plate such as type code, serial number, etc. before calling.

1.8 Environmental protection

NOTICE



Danger for the environment by improper disposal of components or the pedestrian barrier!

In case of improper disposal of components or the pedestrian barrier, damage to the environment may result.

- Observe the local and national laws and directives.
- Disassemble pedestrian barrier according to resources. Sort resources and supply them to recycling.

Safety

2 Safety

2.1 Intended use

The pedestrian barrier is intended exclusively for managing the admission in to areas with restricted access.

In general, the motorized gate is integrated in the fence and gate systems.

The integrated control units MBC and MMC are intended exclusively for controlling the pedestrian barrier.

⚠ WARNING	
	<p>Non-intended use is dangerous!</p> <p>Any use of the barriers other than intended and/or in a different manner can cause hazardous situations.</p> <ul style="list-style-type: none"> – Only use the pedestrian barrier and the control units for the intended use. – All specifications in these operating instructions have to be strictly complied with.

Any types of claims due to damage arising from improper use are excluded. The operator alone shall be responsible for any damage arising from improper use.

2.2 Operator's Responsibility

The operator must comply with the statutory obligations regarding work safety.

In addition to the work safety notes in these operating instructions, the safety, accident prevention and environmental provisions applicable for the area the pedestrian barrier is used in must be complied with.

In particular, the operator must:

- gather information on applicable work protection provisions.
- determine additional danger in a danger analysis.
- implement the required code of conduct for operation of the pedestrian barrier on site in operating instructions.
- regularly verify throughout the pedestrian barrier's time of use that the operating instructions drawn up by him comply with the current state of the regulations.
- adapt the operating instructions to any new provisions, standards and usage conditions - where required.
- clearly determine the responsibilities for installation, operation, maintenance and cleaning of the pedestrian barrier.
- ensure that all employees that are working at or with the pedestrian barrier have read and understood the operating instructions.
- Furthermore, the operator must train personnel regarding the use of the pedestrian barrier at regular intervals and provide information on possible dangers.

Furthermore, the operator is responsible for:

- keeping the pedestrian barrier in perfect technical order and condition at all times.
- maintaining the pedestrian barrier according to the maintenance intervals and performing the safety inspections as stipulated.
- checking all protective facilities for completeness and proper function at regular intervals.

The operator is also responsible that the danger area of the pedestrian barrier cannot be accessed by any unauthorised persons, and in particular not by children, under any circumstances.

2.3 Changes and modifications

Changes and modifications of the pedestrian barrier can cause unforeseen danger.

A written authorisation of the manufacturer is absolutely required before executing any technical changes and modifications at the pedestrian barrier, the control unit or the control program.

Safety

2.4 Specialists and operating personnel

2.4.1 Requirements

⚠ WARNING	
	<p>Risk of injury in case of inadequate qualification!</p> <p>Improper handling can lead to considerable bodily injuries and property damage.</p> <ul style="list-style-type: none"> – Activities must only be carried out by the individuals designated for that purpose.

The operating instructions specify the following qualification requirements for the different fields of activity:

- **Instructed people**
have been instructed during instructions provided by the operator with regard to the work assigned to them and possible hazards arising from improper conduct.
- **Specialised staff**
are able, due to their technical training, knowledge and experience as well as their knowledge of the pertinent regulations are able to carry out work assigned to them independently and to recognise potential hazards.
- **Electrical specialists**
are able, due to their technical training, knowledge and experiences as well as knowledge of the relevant standards and regulations, to execute tasks on electrical systems and to independently recognise possible hazards.
In Germany, the electrical specialist must comply with the provisions of accident prevention regulation BGV A3 (e.g. master electrical fitter). Appropriate regulations apply in other countries. The regulations valid there must be observed.

It must be expected that only those people are deployed who carry out their work reliably. People, whose ability to respond is affected, e.g. by drugs, alcohol or medicines, must not be used. Furthermore, the age and profession-specific regulations valid at the operating location must be observed when selecting personnel.

2.5 Personal protective equipment

It is necessary to wear personal protective equipment when dealing with the machine so as to minimize health hazards.

Before carrying out any work, properly put on the necessary protective equipment such as work clothes, protective gloves, safety shoes and eye wear during work.

2.6 Occupational safety and special dangers

The remaining risks resulting from the hazard analysis are specified in the following section.

Observe the safety notes listed here and the warning notes mentioned in the other chapters of these instructions to reduce health hazards and to avoid dangerous situations.

2.6.1 Danger pictograms on the pedestrian barrier

The relevant dangerous areas on the pedestrian barriers can be identified by the following pictograms:

Electric voltage

⚠ DANGER	
	<p>Mortal danger by electric voltage!</p> <p>... indicates life threatening situations caused by electric voltage. Non-observance of the safety instructions causes severe injuries or death. Necessary work may only be carried out by an electrical specialist.</p> <p>This pictogram is fixed on the following component:</p> <ul style="list-style-type: none"> – Cover sheet at the edge profile.

Danger of crushing

⚠ WARNING	
	<p>Danger of crushing!</p> <p>... indicates the presence of components and items moving towards each other. Non-observance of the safety instructions can lead to severe injuries.</p> <p>This pictogram is fixed on the following component:</p> <ul style="list-style-type: none"> – Edge profile, below the mechanic stops.

Safety

2.6.2 Hazard notes and occupational safety

For your own safety and for the protection of the pedestrian barrier, the following information must be observed and complied with:

Electric voltage

⚠ DANGER	
	<p>Mortal danger by electric voltage!</p> <p>Touching live parts can be lethal. Damage to the insulation or to individual components can be lethal.</p> <ul style="list-style-type: none"> – Switch off the power supply immediately in case of damage to the insulation and arrange repair. – Only electrical specialists may carry out work on the electrical system. – Switch off power supply and secure against reactivation before performing any work. Test for absence of voltage! – Never bypass or deactivate fuses. – When replacing fuses observe the correct amperage specification. – Keep moisture and dust away from live parts. Moisture or dust may cause a short circuit.

Electric voltage – missing safety installations

⚠ DANGER	
	<p>Mortal danger by electric voltage!</p> <p>The safety installations that are required according to regional and local regulations must be provided by the customer. Usually these are:</p> <ul style="list-style-type: none"> – Residual current device (RCD) – Circuit-breaker – Lockable 2-pole main switch according to EN 60947-3.

Improper transport

⚠ WARNING	
	<p>Danger by falling down or tilting of a pedestrian barrier!</p> <p>The weight of the pedestrian barrier or heavy parts of it can seriously injure a person and cause serious crushing!</p> <ul style="list-style-type: none">– Have all transport work performed by specialists only.– Depending on the dead weight and size of the components, use a pallet on which the pedestrian barrier can be moved by means of a forklift.– For lifting a pedestrian barrier, use suitable lifting gear that is designed for the weight of the barrier.– Lifting and carrying the pedestrian barrier or heavy parts of it from the pallet should be done by a minimum of two people.

Heavy weight

⚠ WARNING	
	<p>Risk of injury when lifting heavy objects alone!</p> <p>The weight of heavy objects can severely injure a person!</p> <ul style="list-style-type: none">– Carrying the pedestrian barrier and heavy parts and lifting them from the pallet should be done by a minimum of two people.

Insufficient fixing

⚠ WARNING	
	<p>Risk of injury at insufficient fixing!</p> <p>Insufficient fastening of the pedestrian barrier or any single component can severely injure a person and cause severe crushing!</p> <ul style="list-style-type: none">– Before operation ensure the firm attachment of the clamp bolts.– Check the firm fixing of all screws according to maintenance schedule.– Only qualified and skilled personnel are allowed to assemble the pedestrian barrier and the appropriate components.

Safety

Inadmissible operation

⚠ WARNING	
	<p>Risk of injury at inadmissible operation! An inadmissible operation can cause severe injuries.</p> <ul style="list-style-type: none"> – Before operating the pedestrian barriers check all electrical and mechanical functions.

Sharp edges and spiky corners

⚠ CAUTION	
	<p>Risk of injury on edges and corners! Sharp edges and spiky corners can cause skin abrasions and cuts.</p> <ul style="list-style-type: none"> – Work carefully near to sharp edges and spiky corners. – In case of doubt wear protective gloves.

Signposting

⚠ CAUTION	
	<p>Risk of injury by illegible symbols! Labels and signs can become dirty or unrecognisable in the course of time.</p> <ul style="list-style-type: none"> – Always keep safety, warning and operating notes in a well readable condition. – Immediately renew damaged or unrecognisable signs or labels.

3 Technical data

3.1 Dimensions

3.1.1 Motorized gate with barrier tubing

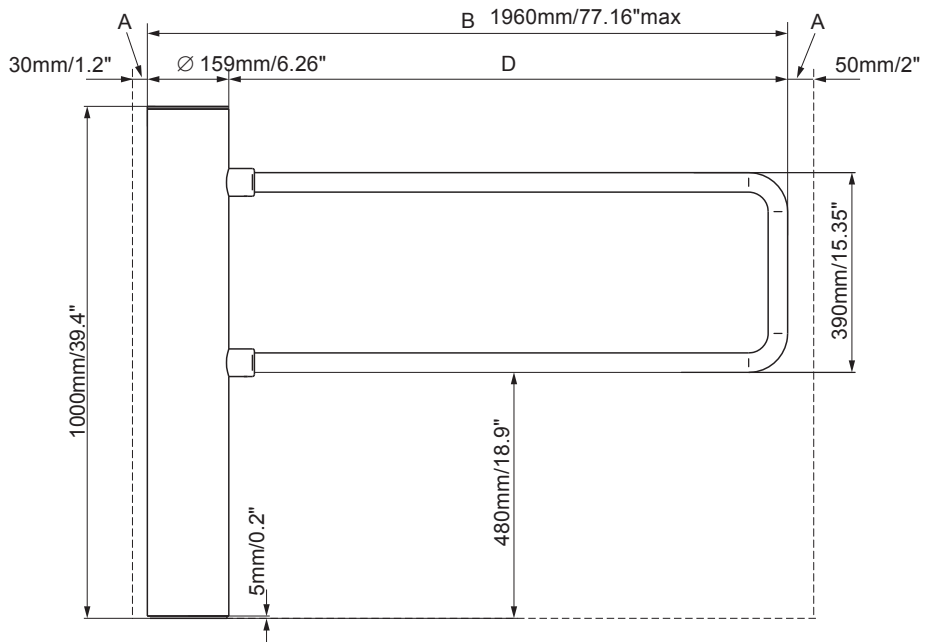

Fig. 1: Dimensions for motorized gate in barrier tube version

- A Safety distances to avoid crushing
- B Total width
- D Bracket length, Standard: 1090mm/42.9", max. 1800 mm/70.9"

Technical data

3.1.2 Motorized gate in wing version

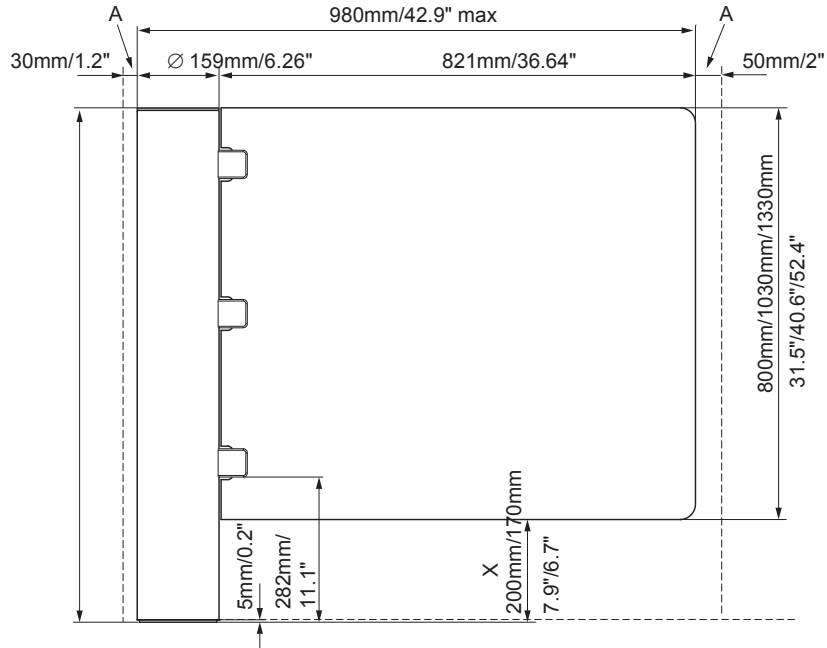

Fig. 2: Dimensions for motorized gate in wing version

- A Safety distances to avoid crushing
- X Floor distance: 200mm/7.9" at wing height 800mm/31.5", 170mm/6.7" at wing heights 1030mm/40.6" and 1330 mm/52.4"

3.2 Electrical connection

Designation	Unit	Motorized gate	
		230 V 50 Hz ¹⁾	115 V 60 Hz ¹⁾
Supply voltage	V AC / Hz	110 to 250 / 50 – 60 Hz	
Current consumption MPS in the resting position	A	0.14	0.16
Power consumption MPS in the resting position	W	12	11
Max. current consumption MPS in movement	A	0.19	0.29
Max. power consumption MPS in movement	W	24	25
Starting current (approx. 30 ms)	A	1.7	1.7
Control voltage	V DC	42	

1) The values are without heating. Activate heating via the program "MPS-Diag". With the heating activated, the values increase.

Table 1: Electrical connection

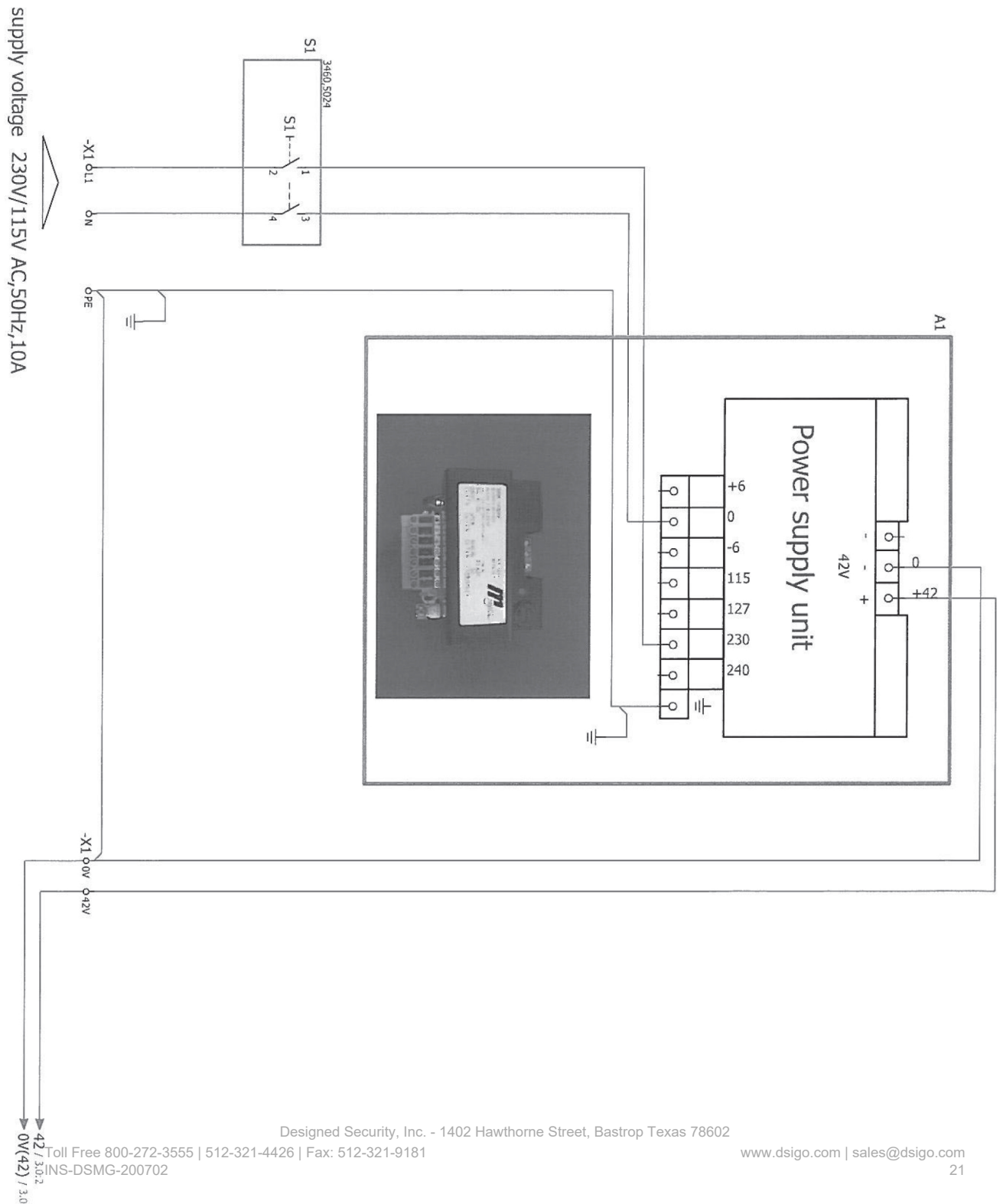

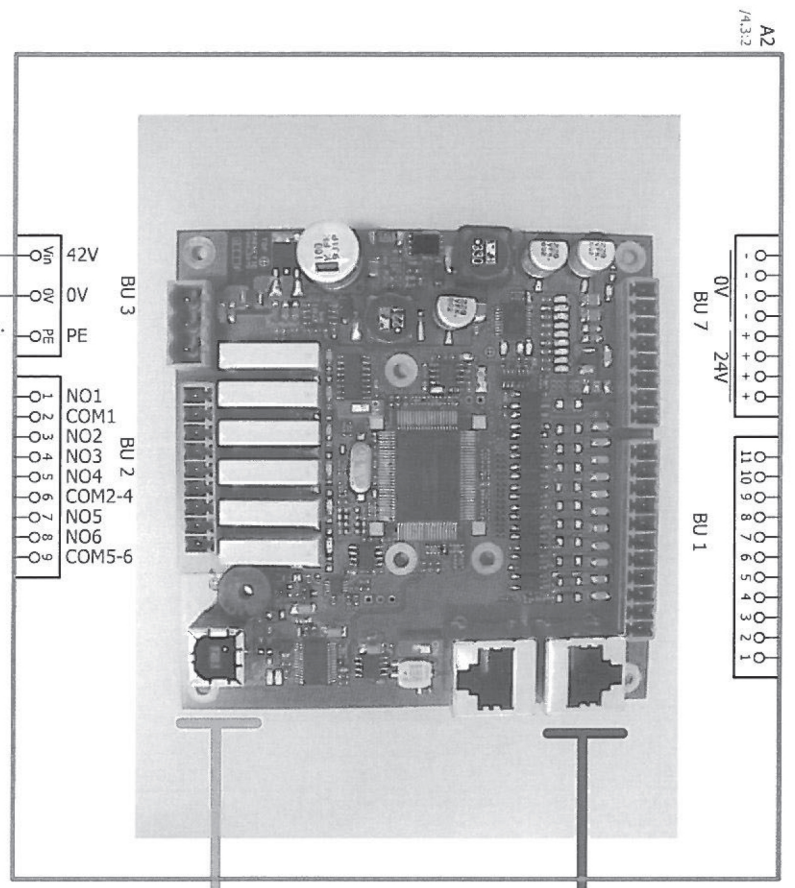

* USB-cable
not fixed

→ MBC 3MMCI20

*
USB-cable with MPS DIAG
software for
parametrization

2.92 / 42
2.92 / 0V(42)

42 / 5.0/2
0V(42) / 5.0/2

input configuration

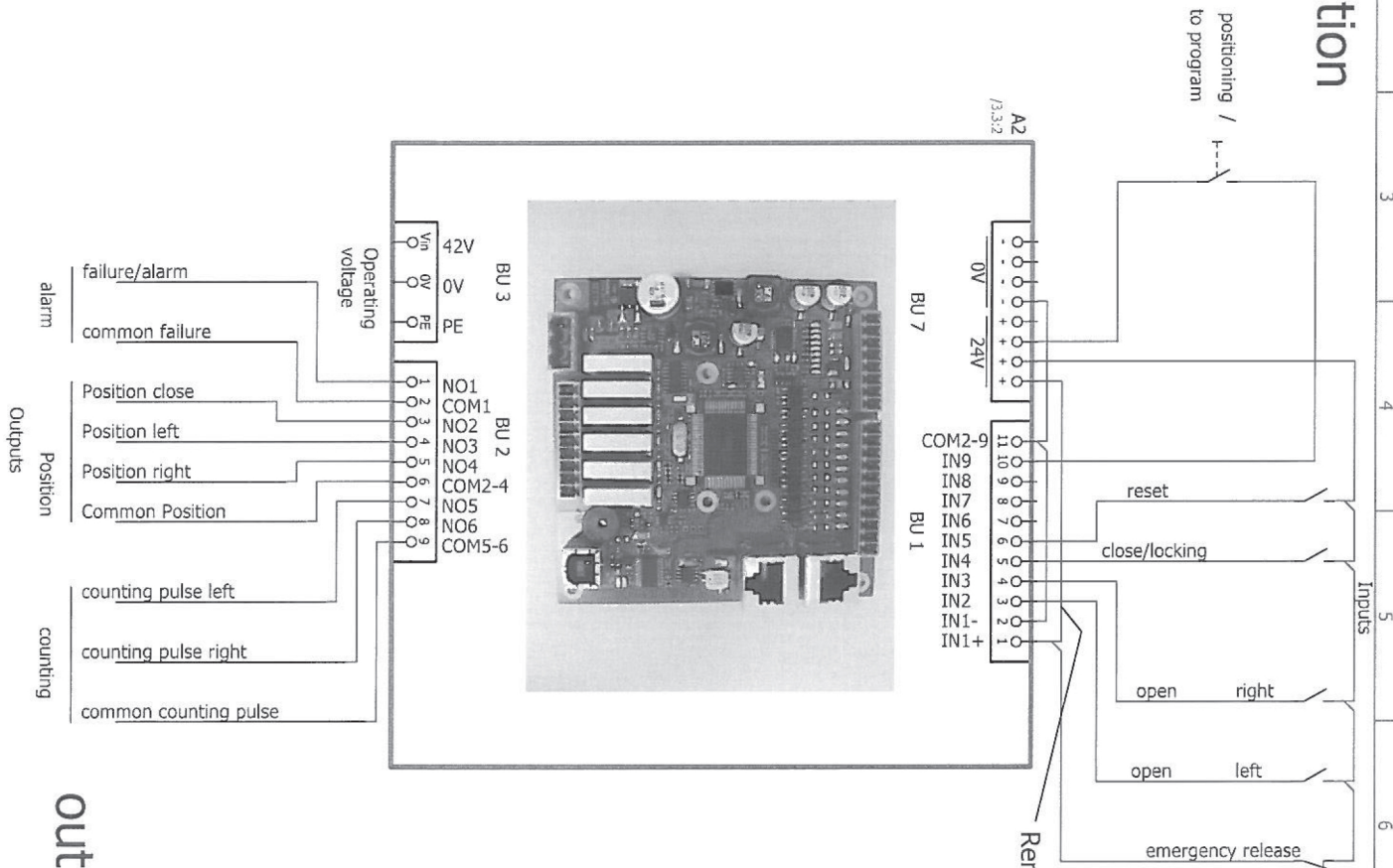

Remove wire bridges when emergency contact is used

output configuration

3.9/2 / 42
3.9/2 / 0V(42)

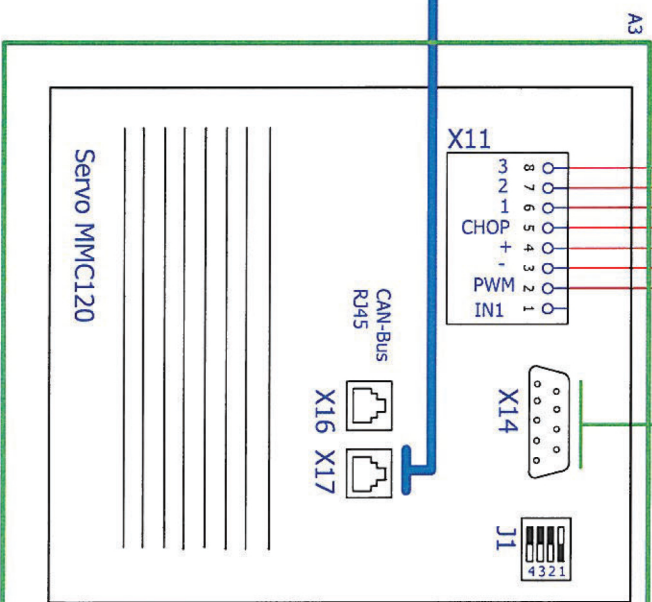
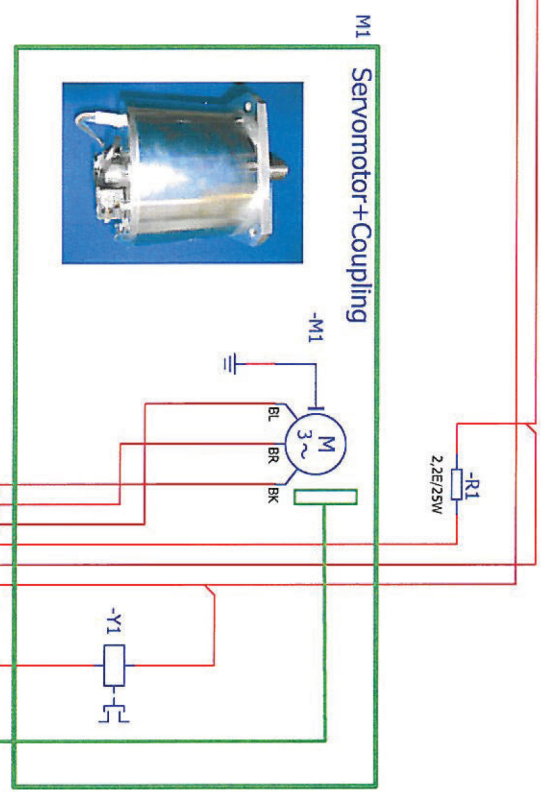

9.2 / MBC_MMCI20
patch cable

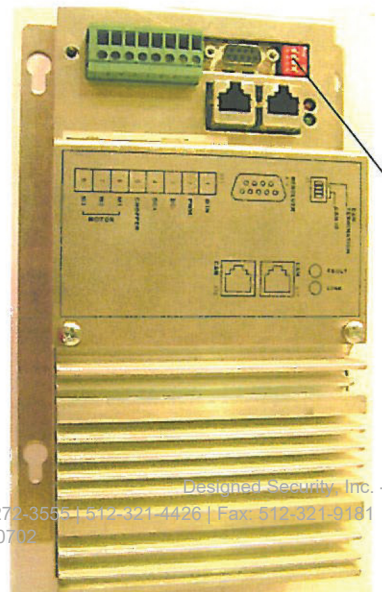

⚠
4 = off
3 = off
2 = off
1 = on
= ID25

3.3 Operating conditions

Designation	Unit	Motorized gate
Ambient temperature range	°C (F)	-25 to +45C (-13 to +113F)
Storage temperature range	°C (F)	-30 to +70C (-22 to +158F)
Relative humidity	% r.F	max. 95 %, non-condensing
Protection class	–	IP 44

Table 2: Operating conditions

3.4 Weight

Designation	Unit	Motorized gate
Weight	kg/lbs	40kg/88.2lbs

Table 3: Weight

3.5 Performance data

Designation	Unit	Motorized gate
Runtime for 90°	seconds	adjustable from 1.5 to approx. 4.0

Table 4: Performance data

Design and function

4 Design and function

4.1 Design

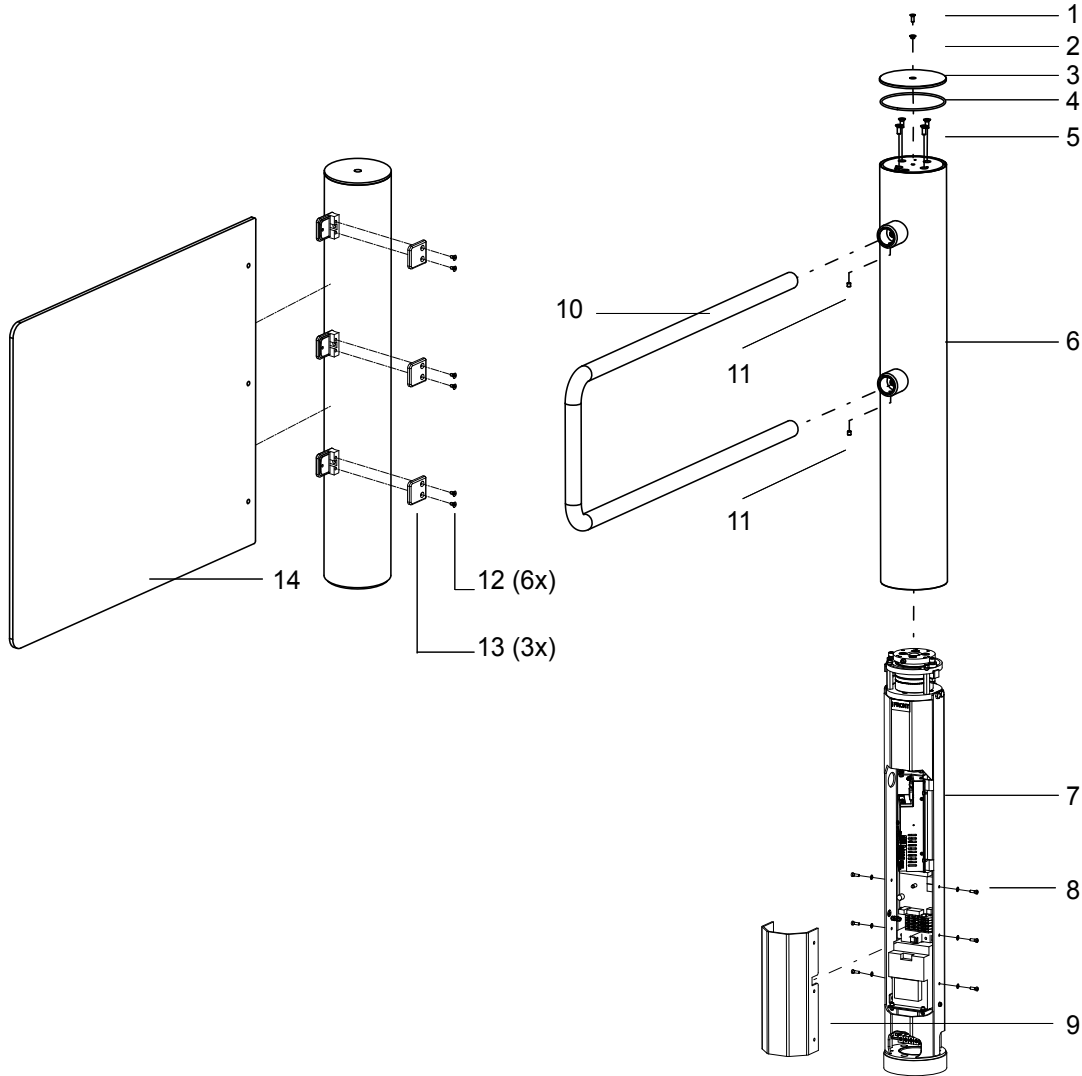

Fig. 3: Structure of components

- | | | | |
|---|---|----|------------------------------------|
| 1 | Countersunk screw M6 x16 | 8 | Disc/screws M5 x 16 |
| 2 | Isolation sleeve | 9 | Cover |
| 3 | Top cover disc | 10 | Locking element in bracket version |
| 4 | O-Ring | 11 | Threaded pin |
| 5 | Countersunk screws M8 x 20 | 12 | Countersunk screw M6 |
| 6 | Outer tube | 13 | Holder for locking element |
| 7 | Edge profile (with drive, control units, transformer) | 14 | Locking element in wing version |

4.2 Definition left and right motorized gate

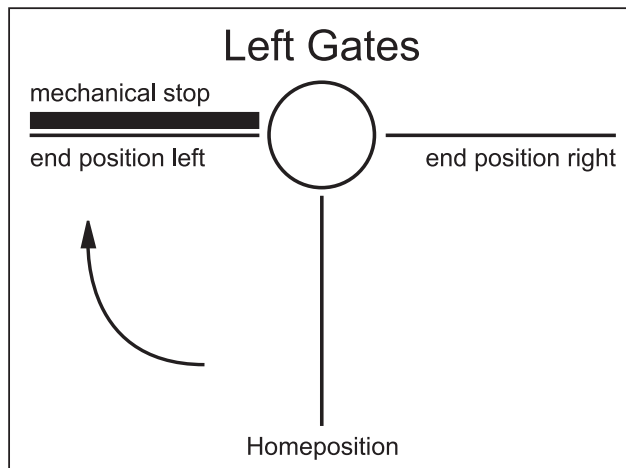

Fig. 4: Version "Left motorized gate"

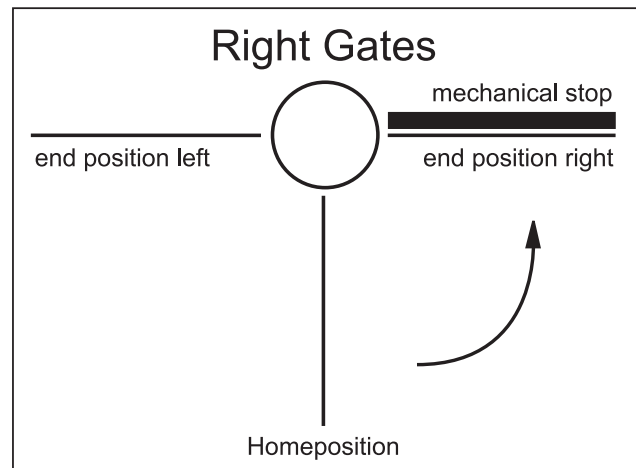

Fig. 5: Version "Right motorized gate"

4.3 Function

The motorized gate is a pedestrian barrier to control access of persons in simple safety applications, usually under supervision.

The motorized gate is also used as a supplement for our turnstiles and wing barriers, in particular for areas where bulky objects must be taken along or persons separated in a wheelchair-accessible manner.

The motorized gate can be operated in two directions. Ex works, the motorized gate is configured for bidirectional operation with a 2 x 90° opening angle. The opening angles may be changed between 10 and 300° by software. Additional parameters such as speed, hold-open time, etc. can be changed by software. The motorized gate is opened by external access control systems and via digital inputs. It is closed fully automatically after the end of an adjustable hold-open time.

The drive system, comprising a Magnetic High Torque Motor MHTM[®] in connection with a planetary gear, ensures a strong and precise sequence of movements. Software can be used to lock the locking element in the two end positions and in the home position, via an electro-mechanical tooth coupling.

If the locking element is pushed from one of its positions by application of strong force, the locking element will swivel automatically back to this position after the force is removed.

The entire drive is nearly maintenance- and wear-free and works without end switch.

If the voltage fails, the motorized gate can swivel freely in both directions.

Assembly and installation

5 Assembly and installation

5.1 Safety

General

⚠ WARNING	
	<p>Danger by inappropriate installation!</p> <p>Inappropriate installation can cause severe injuries!</p> <ul style="list-style-type: none"> – Only qualified personnel, authorised by the operator and instructed appropriately, may carry out installation tasks. – Prior to work, ensure that there is sufficient assembly space. – Pay attention to tidiness and cleanness at the assembly site! Loosely stacked or lying around components and tools are accident sources. – Ensure correct arrangement and correct fit on the components. – Install all fastening elements correctly.

Improper transport

⚠ WARNING	
	<p>Danger by falling down or tilting of a pedestrian barrier!</p> <p>The weight of the pedestrian barrier or parts of it can seriously injure a person and cause serious crushing!</p> <ul style="list-style-type: none"> – Have all transport work performed by specialists only. – Depending on the dead weight and size of the components, use a pallet on which the pedestrian barrier can be moved by means of a forklift. – For lifting a pedestrian barrier or heavy parts of it, use suitable lifting gear that is designed for the weight of the barrier. – Lifting and carrying the pedestrian barrier from the pallet should be done by a minimum of two people.

Heavy weight

⚠ WARNING	
	<p>Risk of injury when lifting heavy objects alone!</p> <p>The weight of heavy objects can severely injure a person!</p> <ul style="list-style-type: none"> – Lifting and carrying the pedestrian barrier or heavy parts of it from the pallet should be done by a minimum of two people.

Improper transport

NOTICE	
	<p>The pedestrian barrier can be damaged by improper transport!</p> <p>Substantial material damage can result from improper transport.</p> <ul style="list-style-type: none"> – Have all transport work performed by specialists only. – When unloading the packages and during in-plant transportation always proceed with greatest care and caution. – Observe the dimensions of the pedestrian barrier. – Loading, unloading as well as moving the pedestrian barrier must take place with greatest care. – Only remove packaging directly before assembly.

Personal protective equipment

The following must be worn during all assembly and installation work:

- Work clothes
- Protective gloves
- Safety shoes.

Assembly and installation

5.2 Requirements for assembly

The following steps are to be completed prior to assembly and installation:

- Laying the foundation.
- Installing the empty conduits.

5.3 Foundation and empty conduits



Note!

To provide trouble-free operation use separate conduits for data cables and mains cables.

The functional safety of the pedestrian barrier hinges on the accuracy of the foundation.

Foundation

The foundation must meet the following requirements:

- Have sufficient load-carrying capacity
- Have a skid-proof surface.
- Horizontal and even, max. deviations 2 mm/m
- Have sufficient thickness for the fastenings.

Empty conduits

The empty conduits must be positioned accurately to the drilling plan. → See page 27, Fig. 6.

Drilling jig

A drilling jig for the tie anchors is part of the delivery.

5.3.1 Foundation plan

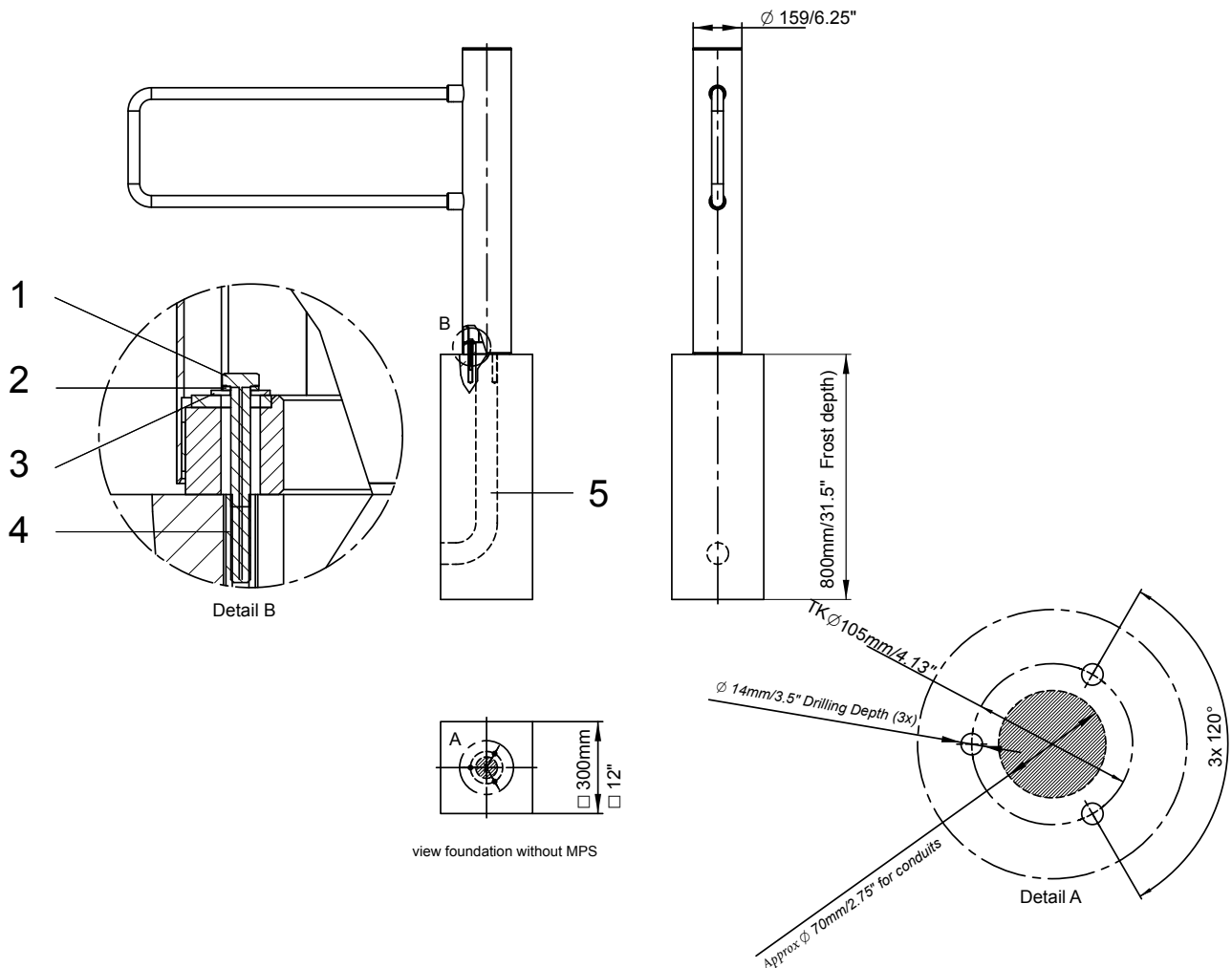

Fig. 6: Foundation plan

- 1 Recessed head screw M8 x 80
- 2 Spring washer
- 3 Disc
- 4 Tie anchor with inner thread M8
- 5 Empty conduits

- Have cables overlap the conduits by approx. 5 m (16.5')
- Tie anchor with inner thread M8
- Drill hole diameter 14mm (0.55") hole depth 90mm (3.5")
- Empty conduits for mains cable and data line
- Foundation level and horizontal
- Concrete or respective consistent industrial flooring
- In case of flagging make sure that the anchor bolts are secured firmly in the foundation. If necessary, use longer bolts.

Assembly and installation

5.4 Mounting the motorized gate

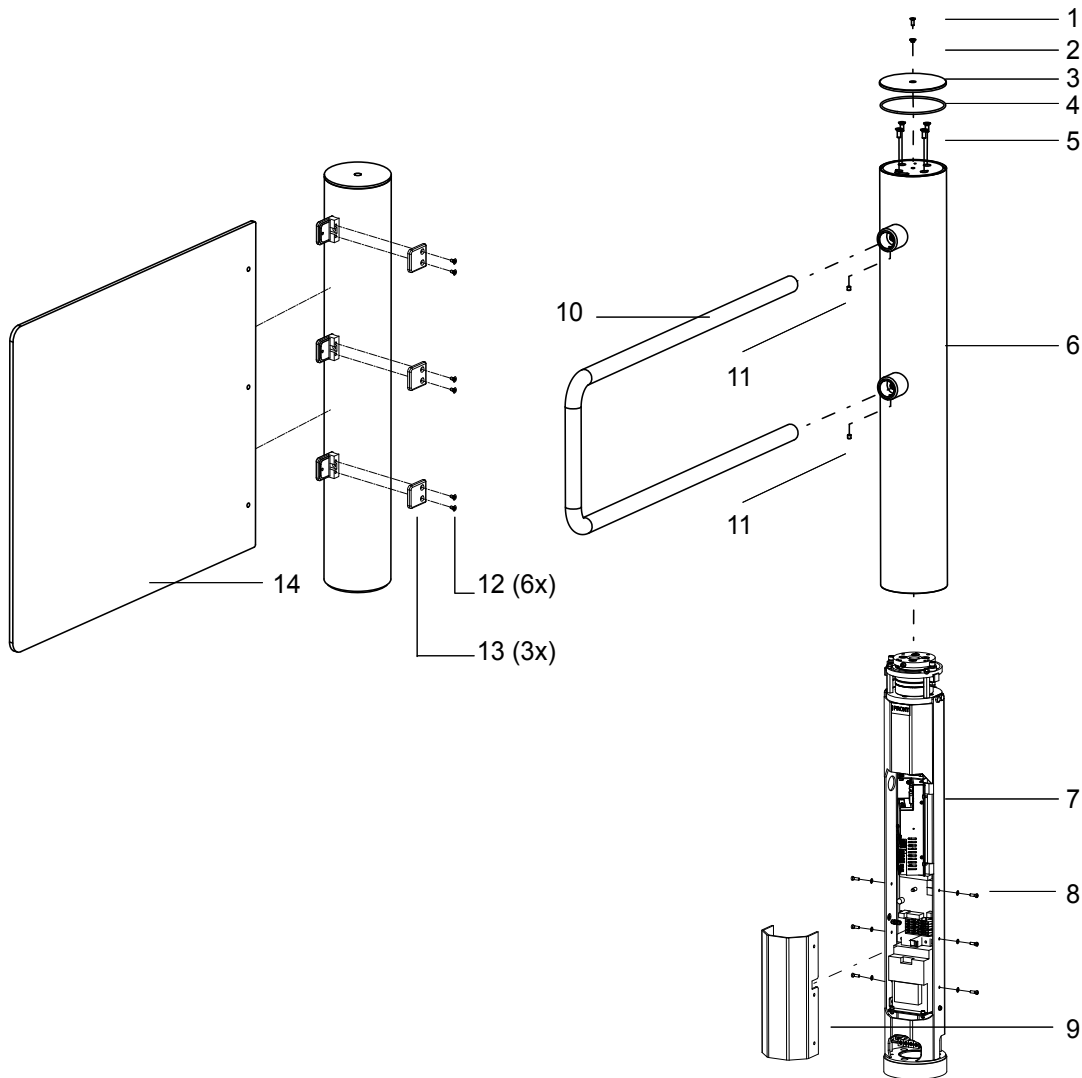

Fig. 7: Mounting the motorized gate

- | | | | |
|---|---|----|------------------------------------|
| 1 | Countersunk screw M6 x16 | 8 | Disc/screws M5 x 16 |
| 2 | Isolation sleeve | 9 | Cover |
| 3 | Top cover disc | 10 | Locking element in bracket version |
| 4 | O-Ring | 11 | Threaded pin |
| 5 | Countersunk screws M8 x 20 | 12 | Countersunk screw M6 |
| 6 | Outer tube | 13 | Holder for locking element |
| 7 | Edge profile (with drive, control units, transformer) | 14 | Locking element in wing version |

5.4.1 Mounting the motorized gate on the foundation



NOTE!

The motorized gate is delivered completely.

The motorized gate has to be partially disassembled before it can be mounted.

The foundation has set to the adequate hardness.

Foundation and empty conduits must be tested prior to commencing assembly.

The motorized gate is fastened with 3 tie anchors on the foundation. The mounting material is included in delivery.

1. Place the bores according to the drilling plan. → See page 27, Fig. 6.
2. Carefully remove any sand and swarf from the bore holes and their immediate vicinity.
3. Set the dowels supplied as shown on the enclosed description and allow hardening.

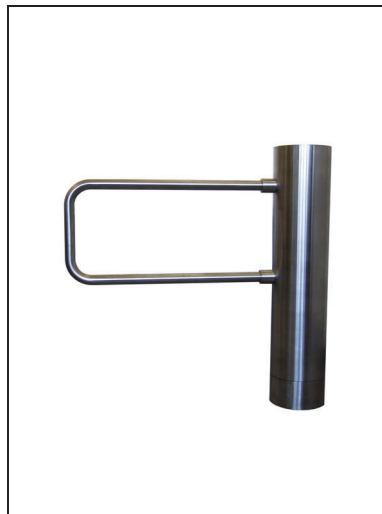

Fig. 8: Single gate complete

Assembly and installation

For installation of the motorized gate, the following work steps are mandatory:

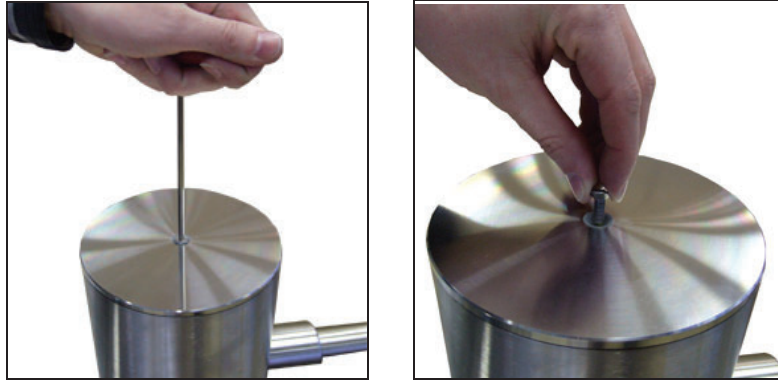

Fig. 9 and 10: Countersunk screw and cover disc

1. Loosen countersunk screw M8 of the cover disc and remove together with the O-ring.
 - Do not allow the screws to come into contact with dust, sand or similar substances.

5.4.2 Disassemble motorized gate

1. Open the top cover disc of the outer tube.



Fig. 11: Cover disc

2. Take off the cover disc and remove the O-ring.



Fig. 12: Countersunk screws

Assembly and installation

3. 4 Loosen the countersunk screws M8 and remove them.

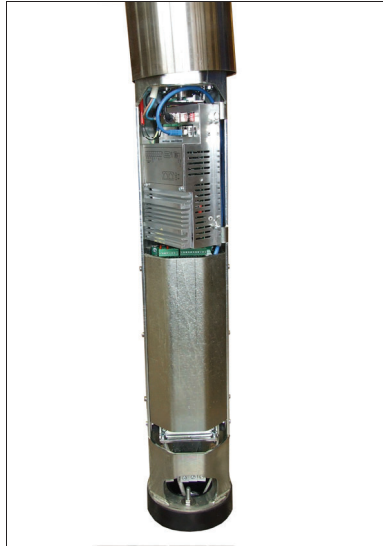

Fig. 13: Outer tube with locking element



Fig. 14: Cover

4. Pull outer tube (Fig. 13) with locking element up and lift off.
5. Loosen screws and remove cover (Fig. 14).
6. Place edge profile at the intended site so that the section in the housing as indicated in Fig. 13 is about central in the direction of the desired home position.
7. Insert supply lines from below.
8. Mark bores.
9. Put edge profile aside again.
10. Drill 3 bores for anchor rods with inner thread M8.
11. Install 3 anchor rods with inner thread M8.
12. Fasten edge profile above the threaded holes. Observe that the conduits with the lines are not damaged.
13. Attach edge profile on the foundation with 3 screws M8.

Assembly and installation

Use the mounting material included in delivery!

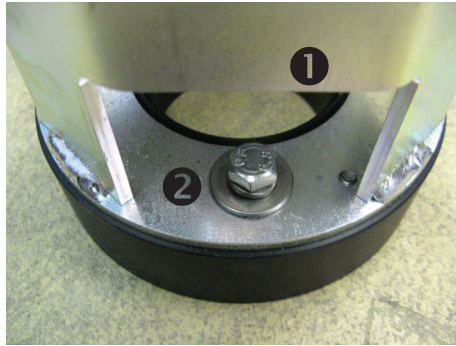

Fig. 15: MPS floor attachment

- 1 MPS edge profile
- 2 Screws M8, spring ring, washer (each 3 x)



NOTE!

Observe curing time for the resin cartridge:

>20 °C (>68°F):	10 min
10 °C to 20 °C (50-68°F):	20 min
0 °C to -10 °C (32-50°F):	1 h
-5 °C to 0 °C (23-32°F):	4 h

6 Electrical connection

6.1 Safety

→ See also safety notes on page 15, chapter 2.6 "Occupational safety and special dangers".

General

⚠ WARNING	
	<p>Danger by inappropriate installation! Inappropriate installation can cause severe or lethal injuries.</p> <ul style="list-style-type: none"> – Only qualified personnel, authorised by the operator and instructed appropriately, may carry out installation tasks. – Pay attention to tidiness and cleanness at the assembly site! Loosely stacked or lying around components and tools are accident sources. – Install all fastening elements correctly.

Electric voltage

⚠ DANGER	
	<p>Mortal danger by electric voltage! Touching live parts can be lethal. Damage to the insulation or to individual components can be lethal.</p> <ul style="list-style-type: none"> – Switch off the power supply immediately in case of damage to the insulation and arrange repair. – Only electrical specialists may carry out work on the electrical system. – Switch off power supply and secure against reactivation before performing any work. Test for absence of voltage! – Never bypass or deactivate fuses. – When replacing fuses observe the correct amperage specification. – Keep moisture and dust away from live parts. Moisture or dust may cause a short circuit.

Electrical connection

Electric voltage – missing safety installations

⚠ DANGER	
	<p>Mortal danger by electric voltage!</p> <p>The safety installations that are required according to regional and local regulations must be provided by the customer. Usually these are:</p> <ul style="list-style-type: none"> – Residual current device (RCD) – Circuit-breaker – Lockable 2-pole main switch according to EN 60947-3.

Electromagnetic interference

NOTICE	
	<p>Electromagnetic interferences may cause malfunctions of the pedestrian barrier or adjacent devices!</p> <p>The pedestrian barrier is approved for industrial use. Operation in other electro-magnetic environmental conditions may cause interferences or malfunctions.</p> <ul style="list-style-type: none"> – Place control lines and mains cables into separate conduits – Use cables according to the electrical circuit plan. – Only install and apply additional parts approved by DSI. – The electrical and electronically additional parts must be EMC verified and must not exceed the indicated EMC threshold values.

Personal protective equipment

The following must be worn during all electrical work:

- Work clothes
- Protective gloves
- Safety shoes.

6.2 Connecting the power supply

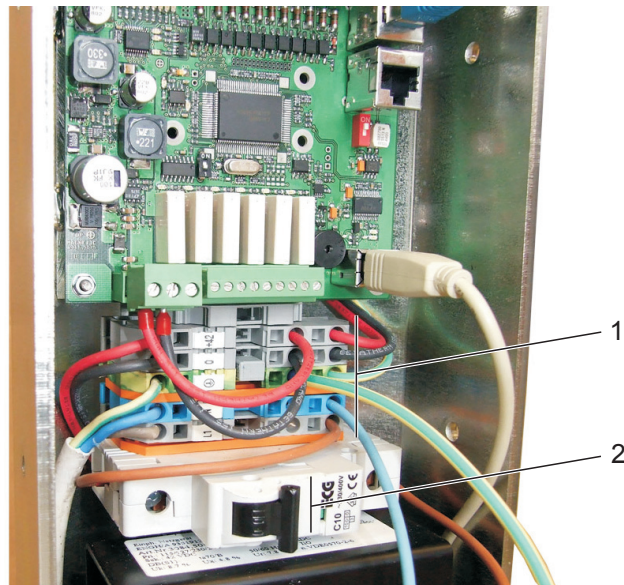

Mag00264

Fig. 16: Power supply connection terminals

- 1 Terminals L, N, PE
- 2 2-pin main switch

Connect the power cable only to the correct terminals L, N, PE (1).
The 2-pin main switch (2) isolates the entire unit.

6.3 Connect control lines to MBC-111

The control and feedback lines are connected at the control unit MBC-111. → See included circuit diagram.

Electrical connection

6.3.1 Digital inputs

- all inputs are insulated by opto couplers
- Input voltage 24V \pm 10%
- Input current 10 mA per input
- Impulse length for inputs 100 ms to 300 ms

Input	Function	Description
1	Emergency situation (Emergency)	<p>This input enables free passage of the swing doors in case of an emergency. The input is fail-safe, i.e. the motorized gate is only operative when a continuous signal is present.</p> <p>When the continuous signal disappears, the motor is switched off immediately. The locking element can be moved freely.</p> <p>The input acts directly on the motor end stage through a second channel. It is superordinate over all other inputs. If several swing doors are to be opened at the same time using an external emergency STOP switch, the inputs must be insulated with additional relays to avoid coupling of the voltages between the different swing doors</p>
2	Open passage left	<p>Opening pulse for passage to the left.</p> <p>If the signal continues to be present, the hold-open time is re-triggered.</p>
3	Open passage right	<p>Opening pulse for passage to the right.</p> <p>If the signal continues to be present, the hold-open time is re-triggered.</p>
4	Closing superordinated (locking)	<p>Input for superordinated closing of the motorized gate. Opening signals at the inputs 2 and 3 are ignored. Opening of the motorized gate above input 1 (emergency situation) continues to be possible.</p>
5	Manual reset	<p>Input for manually resetting the controller after voltage outages. Input is only required when the function "manual reset" was also activated.</p>
6 to 8	Not reserved	–
9	Button connection.	<p>Button for parameterising the home position and hold-open time</p>

Table 5: Digital inputs

6.3.2 Relay outputs

- Isolated relay contacts, wired in groups
- Switched voltage 5 – 48V
- Switched current 10 mA – 1 A

Relay output	Function	Description
K1	Global error and alarm output (voltage outage)	When certain errors occur, a continuous signal is given at this output; it continues as long as the error persists. Refer also to the following note. Possible errors are: <ul style="list-style-type: none"> ■ Runtime of the locking element too long = obstacle detected ■ CAN communication with end stage is impaired ■ Hardware error in end stage ■ Software error in end stage ■ Homing function running ■ Power failure ■ Manual reset expected (only if fitted)
K2	Locking element in the home position	A permanent signal is delivered via this output for as long as the locking element is in the home position.
K3	Locking element in the left end position	A permanent signal is delivered via this output for as long as the locking element is in the left end position.
K4	Locking element in the right end position	A permanent signal is delivered via this output for as long as the locking element is in the right end position.
K5	Counting pulse when the left end position is reached	A counting pulse lasting 500 ms is delivered via this output when the left end position is reached.
K6	Counting pulse when the right end position is reached	A counting pulse lasting 500 ms is delivered via this output when the right end position is reached.

Table 6: Relay outputs



NOTE!

Voltage outage is indicated at the global error output; therefore, relay 1 is operated invertedly. This means that the relay is closed as long as there is no error. As soon as one the global errors described above occurs, the relay falls off.

Assemble MPS column

7 Assemble MPS column

Danger of crushing

⚠ CAUTION	
	<p>Danger of crushing!</p> <p>A moving motorized gate can cause crushing.</p> <ul style="list-style-type: none"> – Highest attention is required for mounting, adjustment and maintenance work on the motorized gate

7.1 Mounting the locking element

1. Switch on main switch (Fig. 16, item 1).
2. Attach cover (Fig. 7, item 9) with 6 cylinder screws.
3. Put on outer tube (Fig. 7, item 6) again.
4. Attach locking bracket or glass wings to the outer tube depending on design.
5. Attach locking element to the outer tube
 - Locking element in bracket version
Attach bracket with 2 threaded pins
 - Locking element in wing version
Attach wings with holder and countersunk screws M6.
6. Turn outer tube so that the slot in the top cover disc (Fig. 7, item 3) is about centered above the stop screw.



Fig. 17: Alignment of stop screw

7. Attach the 4 countersunk screws M8 again and tighten them. Do not mount the cover disc yet.

7.2 Adjusting the mechanical end stops

1. Turn outer tube with locking element to the right until the stop screw touches the right end stop.
2. Loosen the screw of the right end stop and move it until the end stop is about 92° to the right of the desired home position.



Fig. 18: Adjusting the right end stop

3. Tighten the screw firmly again.
4. Turn outer tube with locking element to the right until the stop screw touches the left end stop.
5. Loosen the screw of the left end stop and move it until the end stop is about 92° to the left of the desired home position.
6. Tighten the screw firmly again.



Fig. 19: Adjusting the left end stop

7. Taking the motorized gate into operation. → See page 40, chapter 8 "Commissioning". Check during commissioning if moving to the positions works correctly. If the positions are not targeted correctly, align the end stops again.
8. Insert O-ring again.
9. Put on top cover disc
10. Screw on cover disc with O-ring and countersunk screw M8.

Commissioning

8 Commissioning

8.1 Safety

General

⚠ WARNING	
	<p>Danger by inappropriate start-up and operation!</p> <p>Inappropriate start-up and operation can cause severe or lethal injuries.</p> <ul style="list-style-type: none"> – Prior to start of works ensure that the outer tube is correctly mounted.

Electric voltage

⚠ DANGER	
	<p>Mortal danger by electric voltage!</p> <p>Touching live parts can be lethal.</p> <p>Damage to the insulation or to individual components can be lethal.</p> <ul style="list-style-type: none"> – Switch off the power supply immediately in case of damage to the insulation and arrange repair. – Only qualified electricians may carry out work on the electrical system. – Switch off power supply and secure against re-activation before performing any work. Test for absence of voltage! – Never bypass or deactivate fuses. – When replacing fuses observe the correct amperage specification. – Keep moisture and dust away from live parts. Moisture or dust may cause a short circuit.

Personal protective equipment

The following must be worn during commissioning:

- Work clothes
- Protective gloves
- Safety shoes.

8.2 Initial commissioning

Free movement path

Ensure that the motorized gate can take up operation unhindered. The movement path of the locking element must be free.

Initial commissioning

1. Switch on the main voltage.
2. At initial commissioning, the software for the motor control unit MMC-120 may be loaded from the logic control unit first. This process may take up to one minute. Do not switch off the main voltage during this time, since this would require repeating the process. This process will not be necessary when switching on the main voltage in future.
3. The motorized gate performs homing. First the two mechanical end stops and then the home position are controlled.



NOTE!

Functions and parameters can be changed via the program "MPS-Diag".

→ See page 49, chapter 10.

Commissioning

8.3 CAN bus addressing and termination

The MBC-111 logic controller and the MMC-120 motor controller exchange data via a CAN bus line. The MMC-120 controllers must have a fixed CAN address assigned to it. Additionally, a termination resistor must be activated at both ends of the bus to prevent interference.

Setting the CAN address and termination is performed by DIP switches for both control devices.

The following DIP switch settings are correct:

Function	DIP switch	MBC-111	MMC-120
Termination	1	ON	ON
CAN address	2	OFF	OFF
	3	OFF	OFF
	4	OFF	OFF

Table 7: Setting of the DIP switches

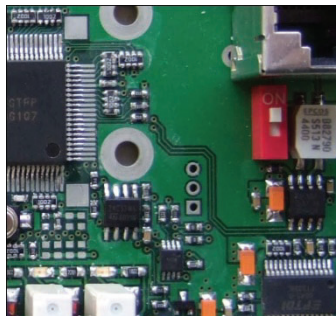

Fig. 20: DIP switch
CAN MBC-111

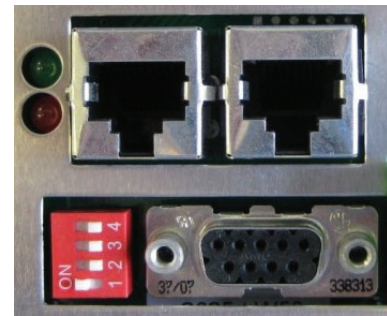

Fig. 21: DIP switch
CAN MMC-120



NOTE!

Wrong settings for the DIP switch can lead to the swing doors not going into operation or to malfunctions during operation.

8.4 Setting the home position and hold-open time via button

You may set the home position and the hold-open time via a button. The button is below the cover disc. → See page 22, Fig. 3

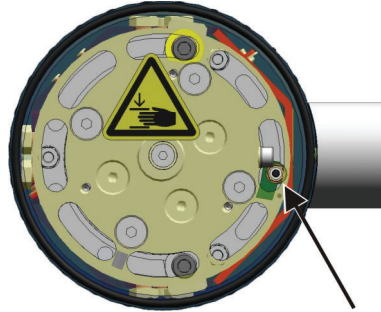

Fig. 22: Button for setting the home position and hold-open time

8.4.1 Setting the home position

Free movement path

Ensure that the motorized gate can take up operation unhindered. The movement path of the locking element must be free.

You may perform homing via the button at the control unit.

1. Push the button. The buzzer emits a signal every time the button is pushed. After 5 seconds, the buzzer emits a signal at 6 Hz twice.



NOTE!

If you do **not** push the button again within the next 10 seconds, the process will be cancelled. The buzzer emits a signal at 2 Hz twice and the locking element swivels back to its original home position. The original home position remains valid.

2. Swivel the locking element to the desired home position.
3. Confirm the position by pushing the button again within the next 10 seconds. The buzzer confirms the new homing position with a continuous signal of 2 second.



NOTE!

If you do **not** push the button again within the next 10 seconds, the process will be cancelled. The buzzer emits a signal at 2 Hz twice and the locking element swivels back to its original home position. The original home position remains valid.

Commissioning

4. After 3 seconds, the locking element automatically swivels to the first end stop. The buzzer emits a signal at a cycle of 1 Hz during the movement.
 5. The locking element briefly remains in the first end position.
 6. The locking element automatically swivels to the second end stop. The buzzer emits a signal at a cycle of 1 Hz during the movement.
 7. The locking element briefly remains in the second end position.
 8. The locking element automatically swivels to the new home position. The buzzer emits a signal at a cycle of 1 Hz during the movement.
 9. After one second, the buzzer emits two signals at 6 Hz.
- The home position is set.

8.4.2 Set hold-open time

You may set the hold-open time using the button at the control unit.

- Setting range: 1...25 s
- Factory setting: 8 s

1. Push button three times within 5 seconds. The buzzer emits a signal every time the button is pushed. After 5 seconds, the buzzer emits a signal at 6 Hz twice.



NOTE!

*If you do **not** push the button three times within 5 seconds, the process will be cancelled. The original hold-open time remains valid. The buzzer emits a signal at 2 Hz twice.*

2. Push the button to set the desired hold-open time. One push corresponds to one second.
Examples: Push the button once for a hold-open time of one second. Push the button 25 times for the maximum hold-open time of 25 seconds.
3. Wait for 5 seconds. After 2 seconds, the buzzer emits a signal at 6 Hz twice. The number of pushes of the button is assumed for the hold-open time.

The hold-open time is set.



NOTE!

*If you do **not** push the button for 5 seconds, the number of pushes of the button is assumed for the new hold-open time value.*

9 Function description

9.1 Power-off state

When there is no voltage, the motor is powered down. It is unlocked. The swing doors can be turned freely.

9.2 Start-up routine

After switching on the operation voltage, the reset version set is checked first.

In case of the setting "manual reset", the control is first waiting for a reset pulse at the "manual reset" input and then performs homing. With the "autoreset" setting, homing is performed at once.

9.3 Homing

The motorized gate first performs "Homing", i.e. it first determines where the locking element is located by first looking for the mechanical end stop. This takes place at a reduced speed and reduced motor torque. During "Homing", the buzzer gives warning signals. Depending on whether a left or right motorized gate has been selected, Homing takes place in different directions.

At a left motorized gate, the locking element slowly swivels clockwise to the mechanical end stop after power returns. After reaching the end stop, the locking element slowly swivels counter-clockwise into the position defined as home position (factory settings: 90°). After the home position is reached, the motorized gate is ready for operation.

At a right motorized gate, the locking element slowly swivels counter-clockwise to the mechanical end stop after power returns. After the end stop is reached, the locking element slowly swivels clock-wise into the position defined as home position (factory setting: 90°). After the home position is reached, the motorized gate is ready for operation.

Depending on the setting for the function "Brake locked in the home position", the brake is tripped accordingly when the home position is reached.

Function description

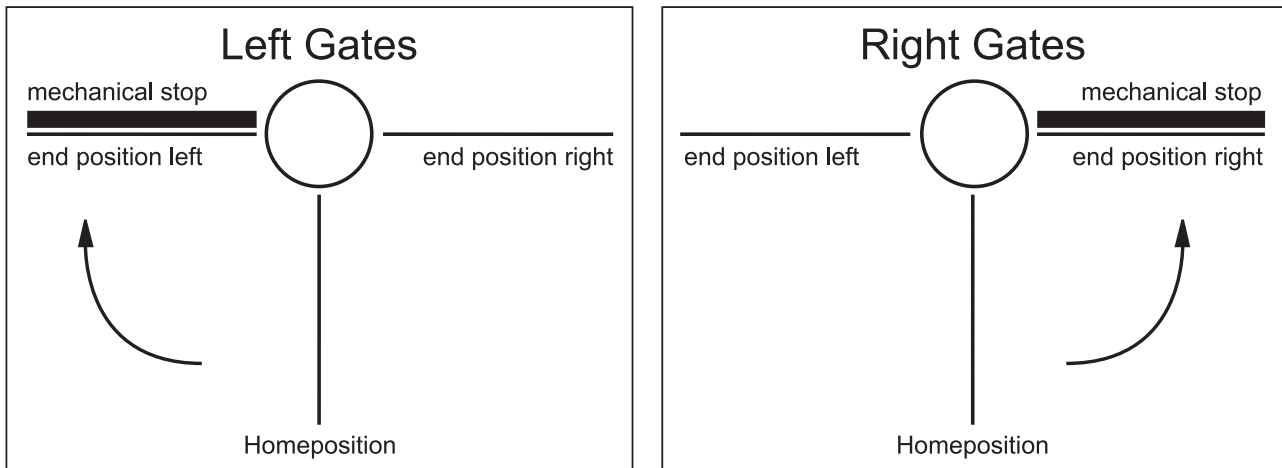

Fig. 23: Homing at a left and right motorized gate

9.4 Regular movement process

In the two end positions and the home position, the motorized gate is held by a motor at a high motor torque. If the function "Activate brake" is chosen for one or several positions, the motor in the corresponding position is powered down and the brake is powered instead.

If no release has been given for one of the two opening directions, the locking element is in the home position. Once an attempt is made to move the locking element from the home position, the brake is activated. Refer to page 47, chapter 9.5.

After a release impulse is reached for one direction, the motorized gate is opened in the passage direction. When the end position is reached, the locking element is moved into position by the motor.

After the hold-open time is over, the motorized gate closes on its own, i.e. the locking element swivels back to the home position.

9.5 Special cases within motion sequence

9.5.1 Obstacle recognition during the movement

The behavior can be set via the parameter "Stalled behavior (Behavior when obstruction detected)". → Refer to page 57, chapter 10.4.5.

The locking element can be stopped in mid-movement, e.g. when a user does not continue on or a luggage piece is caught. Depending on the selected function, one of the following measures is performed:

- There is no reaction.
- The locking element continues to push with a reduced force and speed.
- The locking element returns to the original position and starts the movement again at once.
- The locking element swivels back only a little bit, reverses and swivels on into the original direction again.

9.5.2 Turning back during the movement

The behavior can be set via the parameter "Brake options".
→ Refer to page 56, chapter 10.4.2.

Option "Brake on if vandalism" is activated

If an attempt is made to move the locking element in the wrong direction, the brake is activated at once. After a break, the brake is loosened again. If the attempt to push the locking element in the wrong direction is continued, the brake is activated again.

Once the outer force on the locking element is removed, the lock is loosened and the locking element is automatically moved into the intended direction.

Option "Brake always off" is activated

Turning back the locking element against the motor torque during the movement is possible at any time without damaging the motorized gate. Once the outer force on the locking element is removed, the locking element is automatically moved to the intended position.

Function description

9.5.3 Attempted vandalism

The behavior can be set via the parameter "Brake options".
→ Refer to page 56, chapter 10.4.2.

Option "Brake on if vandalism" is activated

Once an attempt is made to move the locking element from the home position, the brake is activated. If the locking element is pushed or pulled with higher force than the holding force of the brake, the brake will give and tighten again at once. This permits using the locking element further in small steps. If the vandalism attempt is cancelled, the locking element swivels back to the home position.

Option "Brake always off" is activated

The home position is only held by the motor torque. If pushing or pulling the locking element at a higher force than the holding force of the motor, the locking element can be swivelled against the motor torque. Once the outer force on the locking element is removed, the locking element turns back to the home position.

9.5.4 Emergency

If the input IN1 "Emergency" is interrupted during operation, the motorized gate enters a safe state. The motor powers down at once. The control system returns to operation when there is voltage at the input IN1 again.

Setting motorized gate parameters – "MPS-Diag"

10 Setting motorized gate parameters – "MPS-Diag"

The motorized gate is configured so that it can be commissioned without additional programming for applications with an opening angle of 2 x 90°.

Functions and parameters can be changed on site via the program "MPS-Diag". The program is included on a data carrier.

Additionally, a laptop/PC and USB extension are needed.

System requirements

- Windows as of WIN 2000
- USB interface as of 1.1
- Program and operating instructions on included flash drive

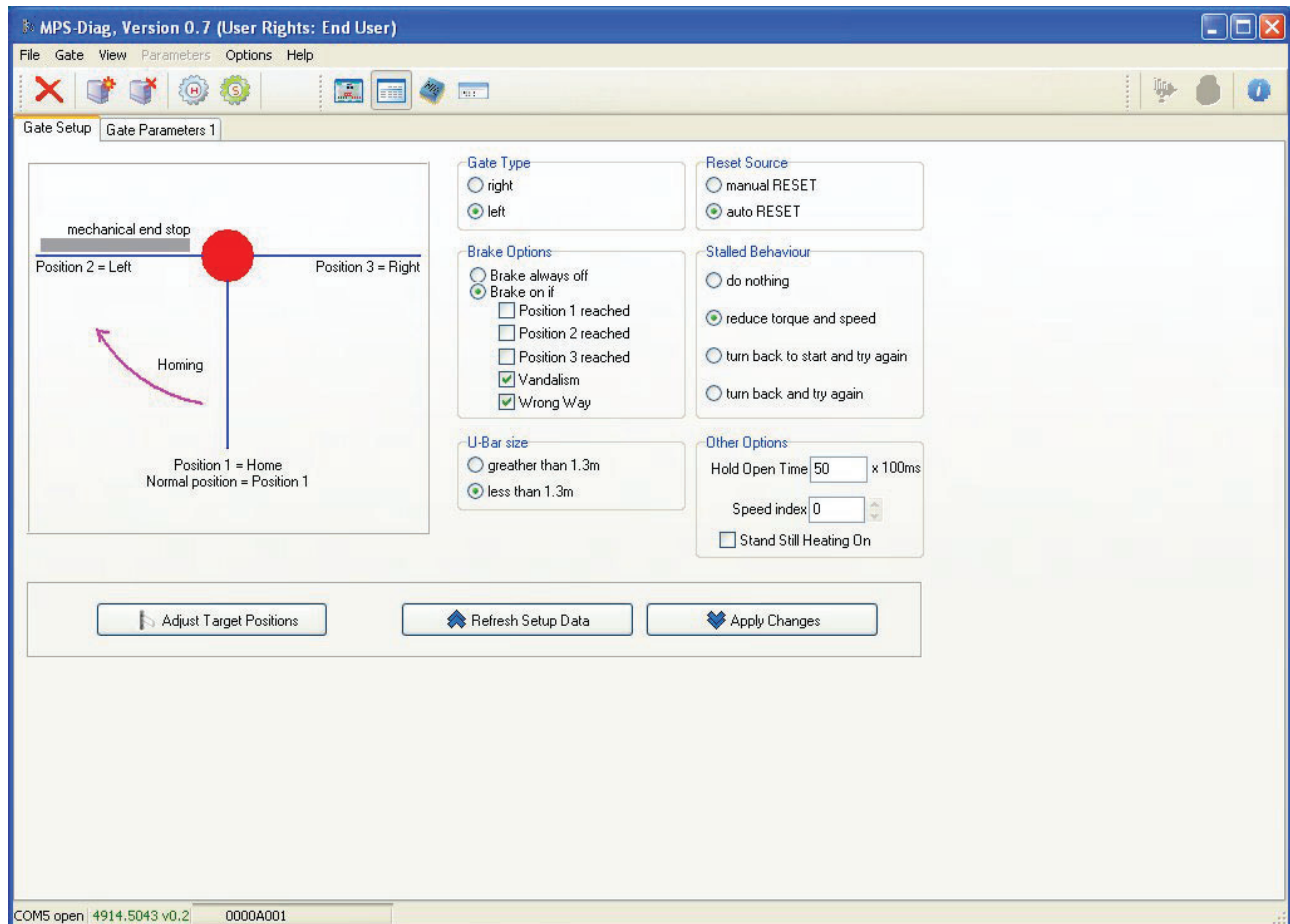

Fig. 24: MPS-Diag program

Setting motorized gate parameters – "MPS-Diag"

10.1 Driver installation under Windows 7

To establish a connection with your motorized gate using the program "MPS-Diag", you need to install the necessary drivers and enter the port number in the program "MPS-Diag".

Driver installation possibilities

There are the following options for driver installations:

Automatic driver installation via setup assistant:

- The latest driver from the internet is installed.
- The included driver is installed.

Manual driver installation:

- The latest driver from the internet is installed.
- The included driver is installed.



NOTE!

For more information on the driver, see <http://ftdichip.com/Support/Documents/AppNotes.htm>

10.1.1 Automatic driver installation via setup assistant

Using the driver from the internet

1. Plug the USB cable into the USB socket of the computer.
 - Windows 7 automatically recognises the newly connected hardware and looks for a matching driver online. The message "Installing device driver software" appears on the display.
 - The driver is installed automatically.
 - After successful installation, the screen shows the message "USB Serial Port (COM). The device driver software was installed successfully".
2. Start setup of the program "MPS-Diag".
3. Perform installation according to setup assistant.
4. As a last step, the view "Terminating the MPS-Diag" appears.
5. Deactivate the check box "Install USB driver".
6. Click the button "Finish".
7. Use the "Device Manager" to determine the port number and enter it in the program "MPS-Diag". → See page 52, chapter 10.1.3.
 - If the entry in the device manager is missing, you need to install the included driver. → See following chapter.

Setting motorized gate parameters – "MPS-Diag"

Use included driver

If the installation of the driver by plugging in the USB cable does not work automatically, you need to install the driver subsequently.

1. Start setup of the program "MPS-Diag".
2. Perform installation according go setup assistant.
3. As a last step, the view "Terminating the MPS-Diag" appears.
4. Activate the check box "Install USB driver" to install the included driver automatically.
5. Click the button "Finish".
6. Use the "Device Manager" to determine the port number and enter it in the program "MPS-Diag". → See page 52, chapter 10.1.3.
 - If the entry in the device manager is missing, you need to install the driver manually. → See following chapter.

10.1.2 Manual driver installation

Using the driver from the internet

1. Open the window "Device Manager".
2. Click the entry "USB serial port". The window "Properties USB serial port" is opened.
3. Click the button "Update driver". The screen "Update driver software" appears.
4. Select the option "Automatically search for driver software".
 - Your operating system searches your computer first, then the internet.
 - The driver is installed automatically. After successful installation, the message "The driver software was installed successfully" will be displayed.
5. Use the "Device Manager" to determine the port number and enter it in the program "MPS-Diag". → See page 52, chapter 10.1.3.
 - If the entry in the device manager is missing, you need to install the included driver manually. → See following chapter.
 - Alternatively, you may also download the latest driver under the following link: <http://ftdichip.com/Drivers/VCP.htm>

Use included driver

If you don't have an internet connection, you can simply use the included driver. The driver is located in the directory:

"...\bin\Driver\USB\FTDI\".

1. Unpack file.
2. In the tab "Driver", click the button "Update driver".
3. Click the option "Automatically search for computer for driver software".
4. Enter or select the path for the driver.

Setting motorized gate parameters – "MPS-Diag"

5. Click the button "Continue". The driver is installed.
6. After successful installation, the message "The driver software was installed successfully" will be displayed.
7. Use the "Device Manager" to determine the port number and enter it in the program "MPS-Diag". → See following chapter.

10.1.3 Enter the port number in the program "MPS-Diag".

Successful driver installation

1. Click the icon "Desktop".
 2. Select the menu field "Properties". The window "Basic information" is opened.
 3. Click the entry "Device Manager". The device manager is opened.
- If installation was successful, "Connections (COM & LPT)" will list the "USB Serial Port" with a port number. The port number depends on your computer's configuration.

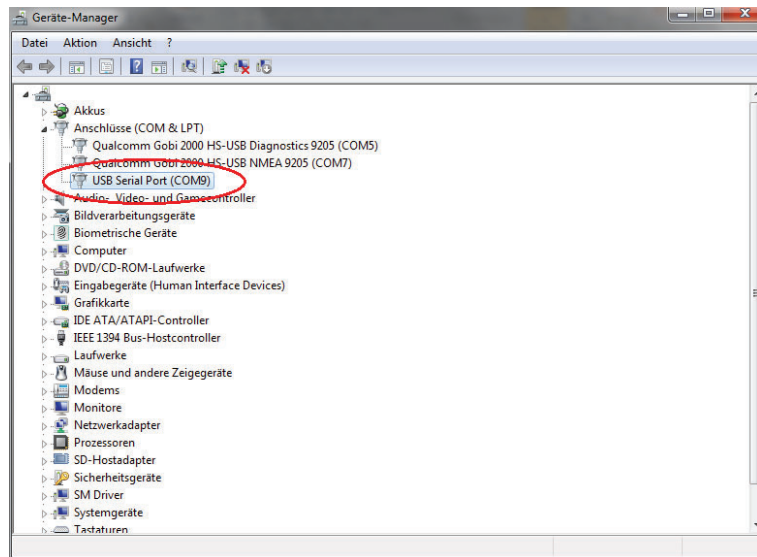

Fig. 25: Entry "USB serial port with port number" (here COM9) at successful installation

4. Call program MPS-Diag
5. Select menu item "Settings".
6. Enter the port number.

Setting motorized gate parameters – "MPS-Diag"

Failed driver installation

- If installation was not successful, no port number is indicated for the connection "USB Serial Port".

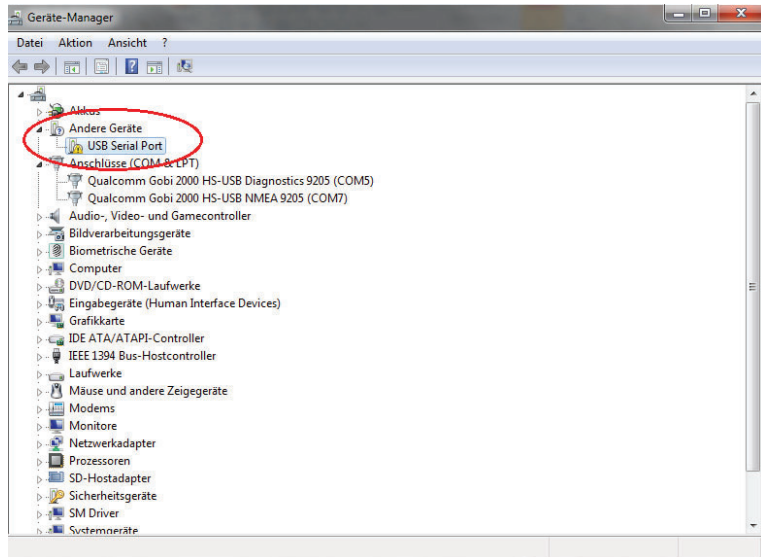

Fig. 26: Missing port number" if the installation has failed

Choose another way of installing the driver. → See page 50, chapter 10.1.1 and page 51, chapter 10.1.2.

10.2 Connect laptop to control device MB-111

Connection of the USB cable is only possible after disassembly of the outer tube with the locking element.

The connection cable is in the socket area.

Connect the MBC-111 with a normal USB extension.



Fig. 27: Connection for USB plug with extension

Setting motorized gate parameters – "MPS-Diag"

10.3 Using the MPS-Diag program

1. Install the program "MPS-Diag" on a laptop or computer
2. Start the included program "MPS-Diag" via Setupxxx.exe and execute the instructions of the installation routine.
3. A virtual COM port driver is installed during installation. The port number of the serial interface is determined as follows:
 - Plug in connection cable.
 - Read the port number in the menu "Device Manager > Connections (COM and LPT)".
4. Start the program "MPS-Diag".
5. If required, select the desired language via the menu "Settings > Language". Restart the program.
6. Select your computer's COM port in the menu "Settings".

Setting motorized gate parameters – "MPS-Diag"

10.4 Function and parameter settings

Function and parameter settings are made through the Windows program MPS-Diag.

The following functions can be set:

- Design left / right
- Brake activated / not activated in the three positions, in case of vandalism or when pressed in the wrong direction
- Present locking element size
- Reset source
- Behavior when obstruction detected
- Hold-open time
- Speeds
- Heating active while standing
- Programming the two end positions and the home position
- Resetting all parameters to factory settings

10.4.1 Version left / right

This selection point informs the control whether it is a right or a left version of the motorized gate. In the "right" version, the locking bracket swivels against the right mechanical end stop when homing. In the "left" version, the locking bracket swivels against the left mechanical end stop when homing.

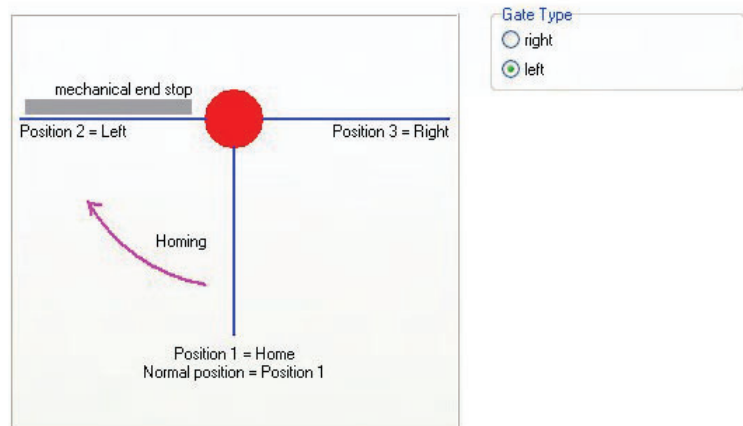

Fig. 28: Explanation on version "Right" and "Left", here the directions for the left motorized gate are presented

Setting motorized gate parameters – "MPS-Diag"

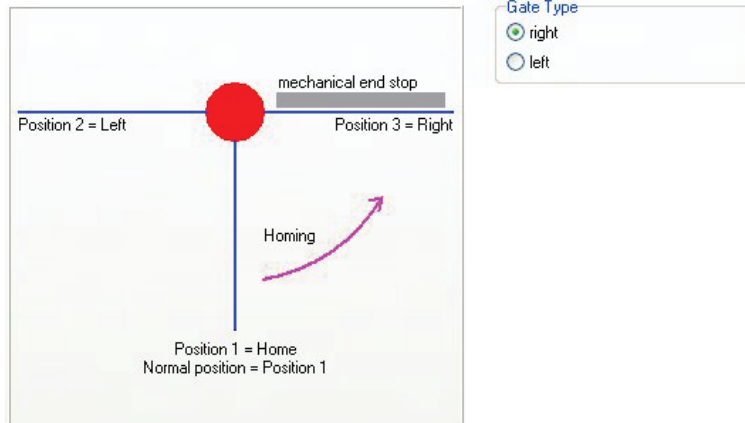

Fig. 29: Explanation on version "Right" and "Left", here the directions for the right motorized gate are presented

10.4.2 Brake activated / not activated

This option is used to inform the control if the brake is to be activated when one of the three positions is reached, in case of vandalism or when pressed in the wrong direction. The setting can be made independently for each of the five options.

Brake Options

Brake always off

Brake on if

Position 1 reached

Position 2 reached

Position 3 reached

Vandalism

Wrong Way

Fig.30: Possible settings for the brake

Setting motorized gate parameters – "MPS-Diag"

10.4.3 Select size of the locking element

Choose the length of the locking bracket via the selection point.



Fig. 31: Select length of the locking bracket

Always select the setting "more than 1.3 m" for swing doors in the wing version.

10.4.4 Select reset source

This option can be used to specify whether, once power has been restored, the controller first waits for a pulse at the "manual reset" pulse or whether it starts to home immediately.



Fig. 32: Select reset source

10.4.5 Stalled behavior (Behavior when obstruction detected)

This selection point determines the behavior of the motorized gate when an obstacle is recognized.

- Do nothing: There is no reaction.
- Reduce force and speed: The locking element continues to push with a reduced force and speed.
- Reverse completely and start anew: The locking element returns to the original position and starts the movement again at once.
- Reverse slightly and start anew: The locking element swivels back only a small bit, reverses and swivels on into the original direction again.

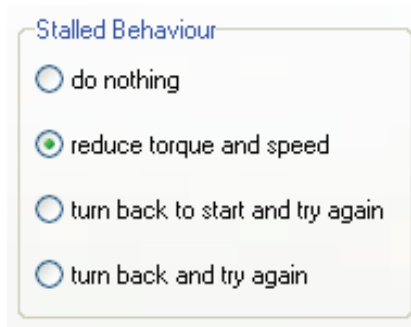

Fig. 33: Stalled behavior (behavior when obstruction detected)

Setting motorized gate parameters – "MPS-Diag"

10.4.6 Set hold-open time

The "hold-open time" parameter is used to set the hold-open time between 0 and 25 seconds in steps of 100 ms. Entering 50 means 5 seconds.



Other Options

Hold Open Time x 100ms

Speed index

Stand Still Heating On

Fig. 34: Set hold-open time

10.4.7 Set speed

The parameter "Speed" sets one of the three specified speeds "0 (slow)", "1 (medium)" or "2" (fast). The speed applies to regular operation.

If you have chosen "more than 1.3 m" for the parameter "U-bar size", the parameter "Speed" only has the option "0 (slow)". Observe that you always have to choose "above 1.3 m" for glass wings. → For the parameter "U-bar size", see page 57, chapter 10.4.3.

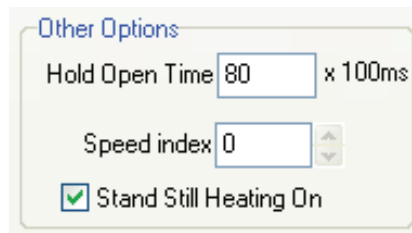

Other Options

Hold Open Time x 100ms

Speed index

Stand Still Heating On

Fig. 35: Set speed

10.4.8 Heating active while standing

This option is used to determine if heating is activated while standing. The heating is needed if the motorized gate is used at ambient conditions below 0°C.

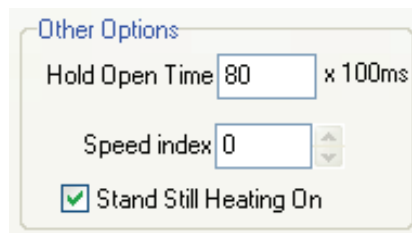

Other Options

Hold Open Time x 100ms

Speed index

Stand Still Heating On

Fig. 36: Switch on standing heating.

Setting motorized gate parameters – "MPS-Diag"

10.4.9 Teaching the three possible positions

The MPS is delivered with 2 x 90° opening angles by default. However, the three positions can be changed independently. For this, there is an input mask in MPS-Diag.



Fig. 37: Activate screen mask for adjusting the target positions

Setting the target positions is a process with several stages.

	Actual Values	Factory Defaults	
Home Position	90,00	90,00	from mechanical end stop
Left Position	90,00	90,00	from the home position
Right Position	-90,00	-90,00	from the home position

Please select one of the following options:

- Don't change anything, use actual positions
- Take over the factory defaults as new target positions
- Adjust some positions within next steps

Fig. 38: Setting the target positions

1. Perform homing. Put the MBC control into service mode for this. Then you can adjust the three positions.

In order to change some of the target positions a homing should be carried out. For this purpose the MBC-Controller will be switched in the 'service mode'.

try to switch into 'service mode'...DONE

try to start homing...DONE

waiting for homing end...

Fig. 39: Perform homing

Setting motorized gate parameters – "MPS-Diag"

2. Adjust "home position".

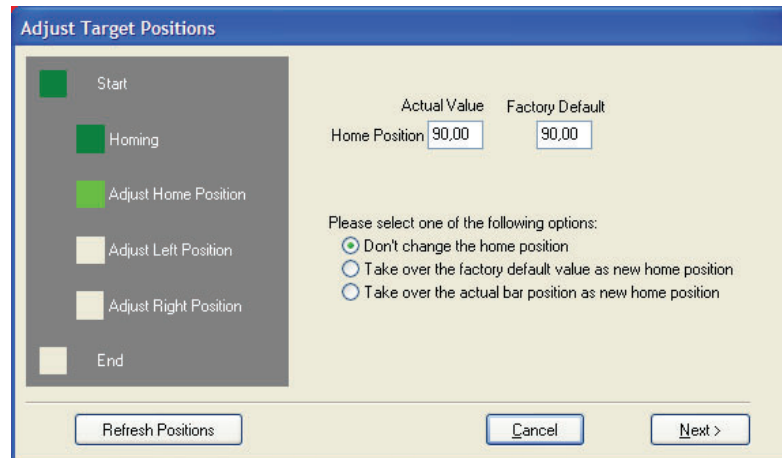

Fig. :40 Adjust home position

3. Adjust "left position".

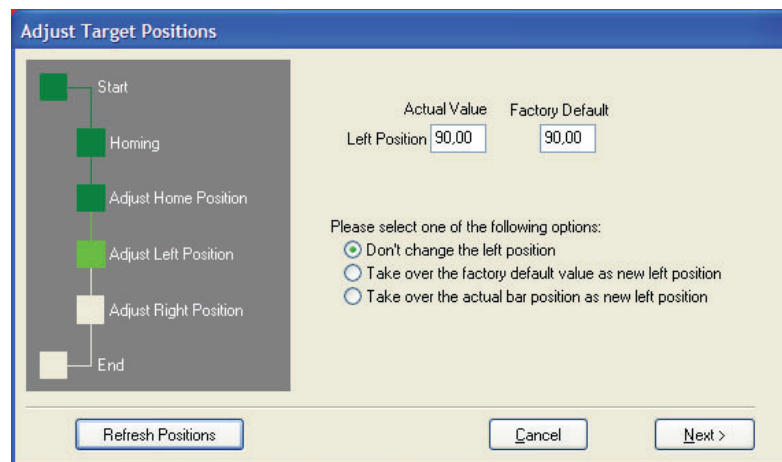

Fig. 41: Adjust "left position"

4. Adjust "right position".

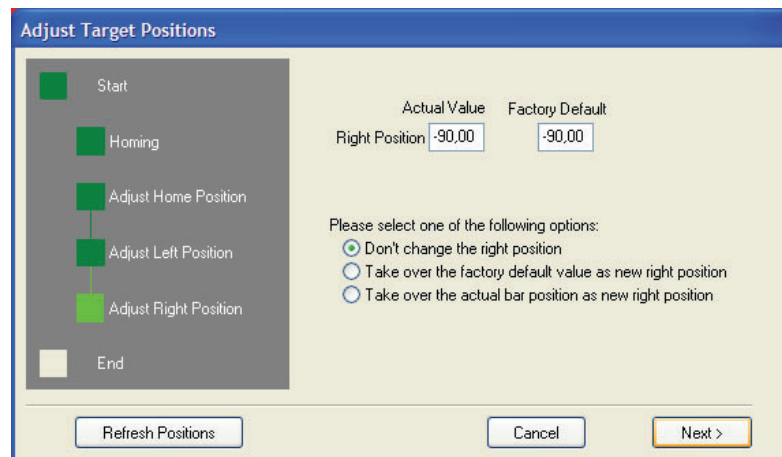

Fig. 42: Adjust "right position"

Setting motorized gate parameters – "MPS-Diag"

- Confirm changes by clicking the button "Close". The MBC control is restarted.

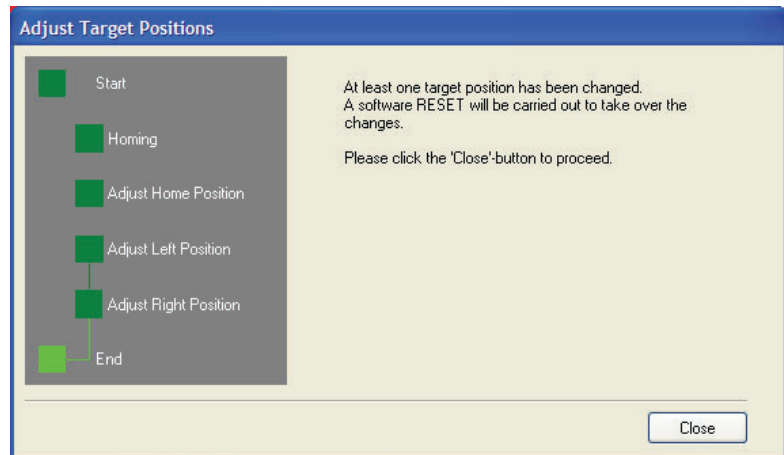

Fig. :43 Reset control MBC

10.4.10 Reset all parameters to factory settings

This option can be used to restore the factory settings for all parameters.

- Open menu "View" and select the item "Parameter".

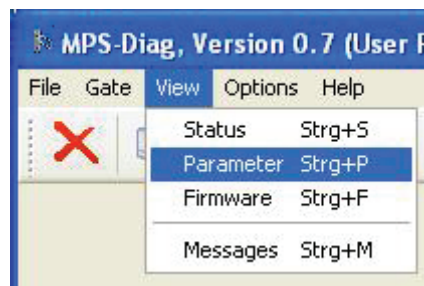

Fig. 44: Menu "Parameter"

- The menu "Parameter" is displayed in the title bar.
- Click menu "Parameter"
- Select menu item "Restore all parameters to factory settings"

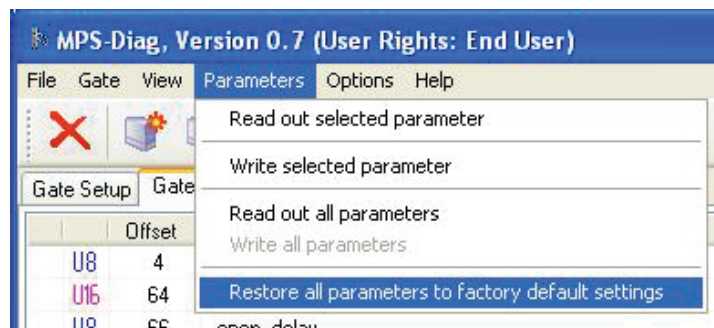

Fig. 45: Select menu item "Restore all parameters to factory settings"

Setting motorized gate parameters – "MPS-Diag"

- Safety confirmation "All parameters are reset to factory settings. Do you want to continue?"

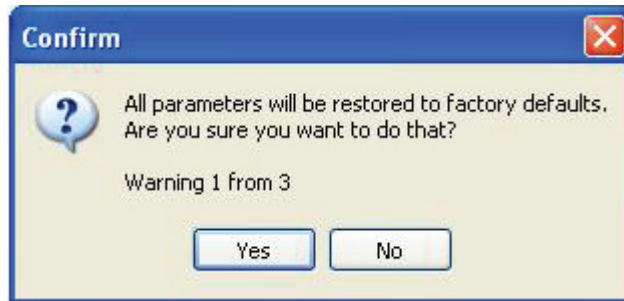

Fig. 46: Safety confirmation

- Clicking "Yes" resets all parameters to factory settings.
- Clicking "No" cancels the process.

10.5 Firmware download

To update the control device firmware, the "MPS-Diag" program is needed.

- Open menu "View" and select the item "Firmware".

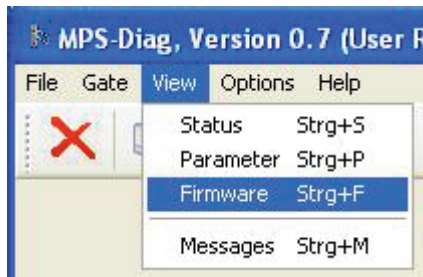

Fig. 47: Menu "View"

Setting motorized gate parameters – "MPS-Diag"

2. A dialogue window appears. The dialogue window display depends on the control type. If communication with the control is impossible, the MBC field will show a question mark.

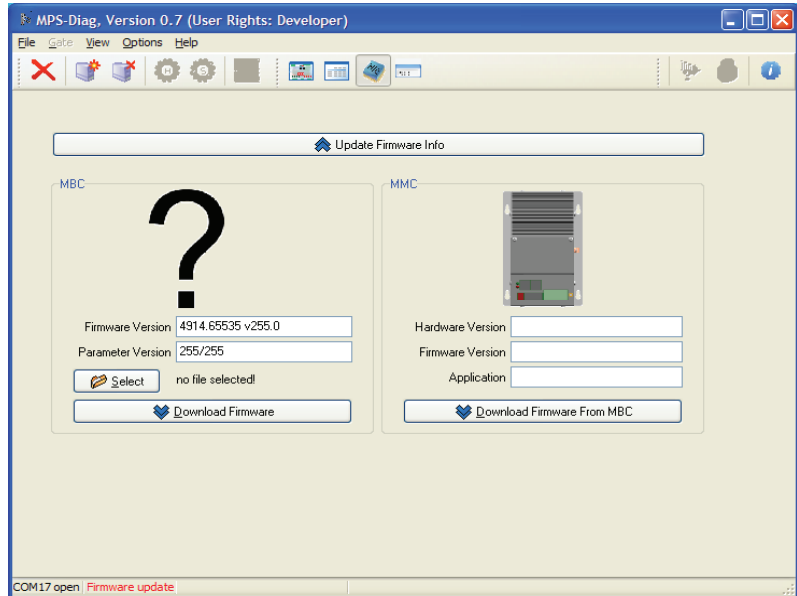

Fig. 48: Menu "Firmware update" (here: no communication)

When communication to the control is present, proceed as follows for downloading a new firmware version:

3. Select the firmware file through the button "Select".
4. Click the button "Download Firmware".

The further process depends on the control type and the file selected. For a MBC111 control, the file type chosen should be a ".mcp" file.

You may also select an ".s" file (Motorola S-Record). This download will take longer.

Setting motorized gate parameters – "MPS-Diag"

10.5.1 Firmware download using a ".mcp file"

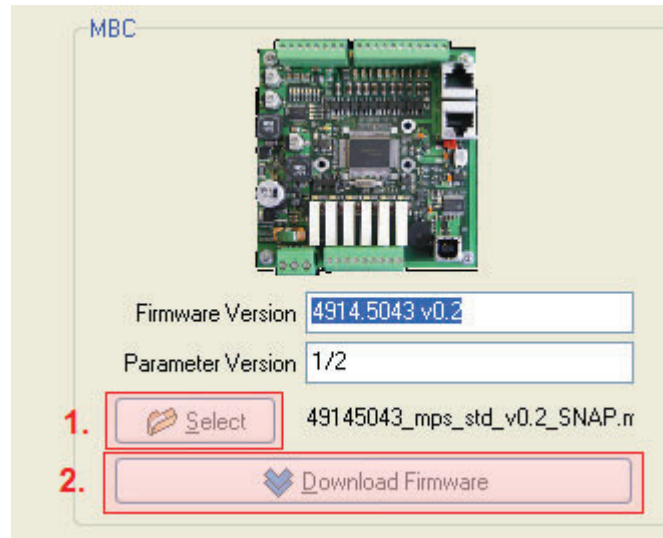

Fig. 49: Button "Download Firmware"

1. After clicking the button "Download firmware", the program status bar shows the download progress.

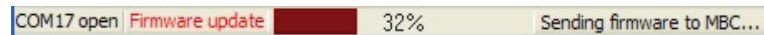

Fig. 50: Download progress

2. When the download is completed, perform voltage reset.

10.5.2 Firmware download using an ".s file"

Only use firmware download using an ".s" file with a MBC111 control if the bootloader is no longer accessible.

1. Select the firmware file through the button "Select".
2. Select the file type in the file selection dialogue.

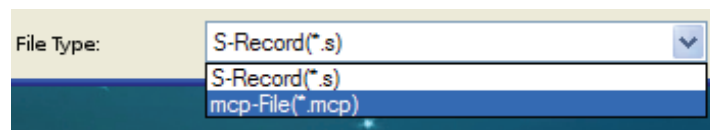

Fig. 51: File type selection

3. Click the button "Download Firmware".
4. Select the integrated control with the dialogue window "Control selection".

Setting motorized gate parameters – "MPS-Diag"

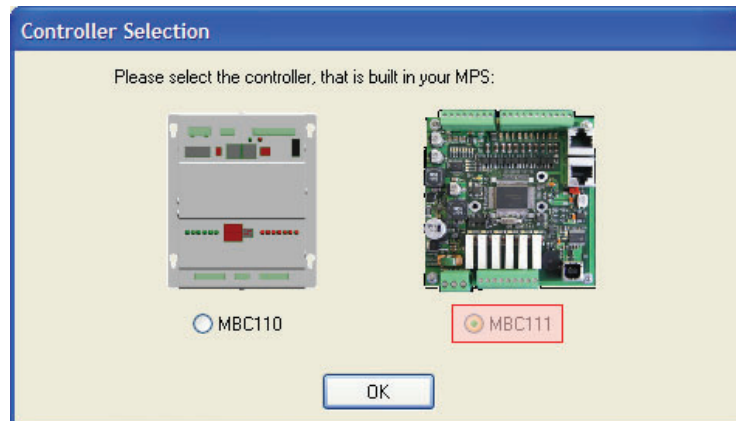

Fig. 52: Control selection

5. The dialogue "Confirmation" is displayed.

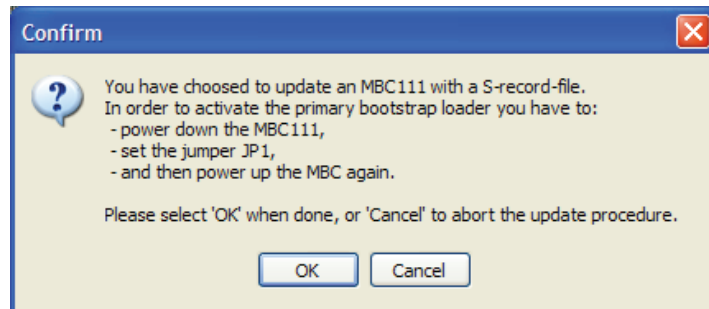

Fig. 53: Dialoge "Confirmation"

6. Observe the dialogue instructions precisely.
7. When you have performed all steps, click the "OK" button.
8. When the connection to the bootloader is established, the download will start. The download progress is displayed in the status bar.
9. After firmware transmission the "Information" dialogue is shown.

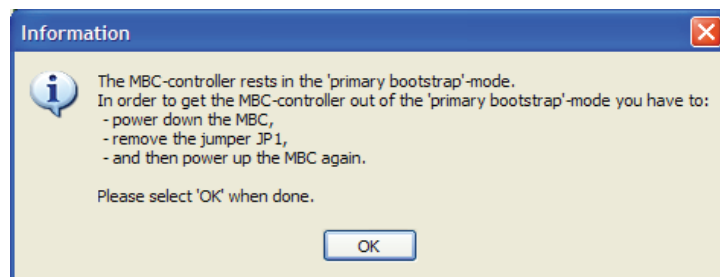

Fig. 54: Dialog "Information"

10. Observe the dialogue instructions precisely.
11. When you have performed all steps, click the "OK" button. The download is completed.

Setting motorized gate parameters – "MPS-Diag"

10.6 Download between MBC-111 and MMC-120

Each time the MBC-111B is booted after voltage is switched on again, software verification is performed between the MBC-111 and the connected motor control device MMC-120. It verifies that the motor control device has the right software and the right software version for the MBC-111 application software.

If verification shows that the motor control device has the wrong software or software version, the correct software is automatically loaded from MBC-111 to MMC-120. The software can also be manually loaded from MBC-111 to MMC-120 through the Windows program MPS-Diag.

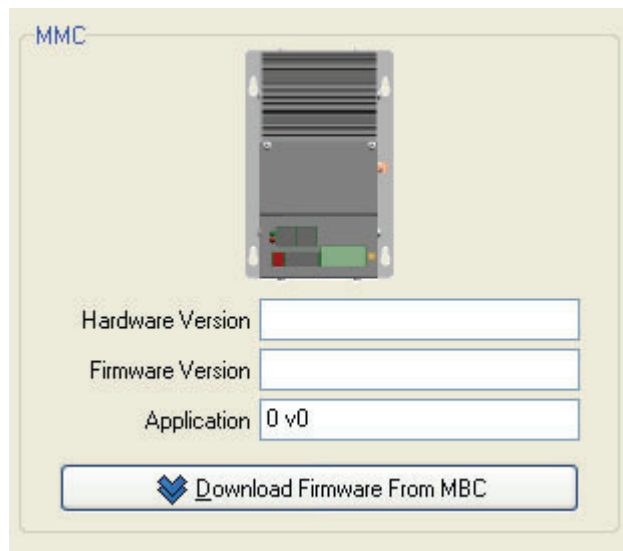

Fig. 55: Programming via the MPS-Diag program

Setting motorized gate parameters – "MPS-Diag"

10.7 Reading errors

Reading the error codes right at the MBC-111 or MMC-120 is only possible after disassembly after removing the outer tube with the locking element. Therefore, the program MPS-Diag offers the possibility of reading errors from the MBC-111 and MMC-120 controls through the serial interface.

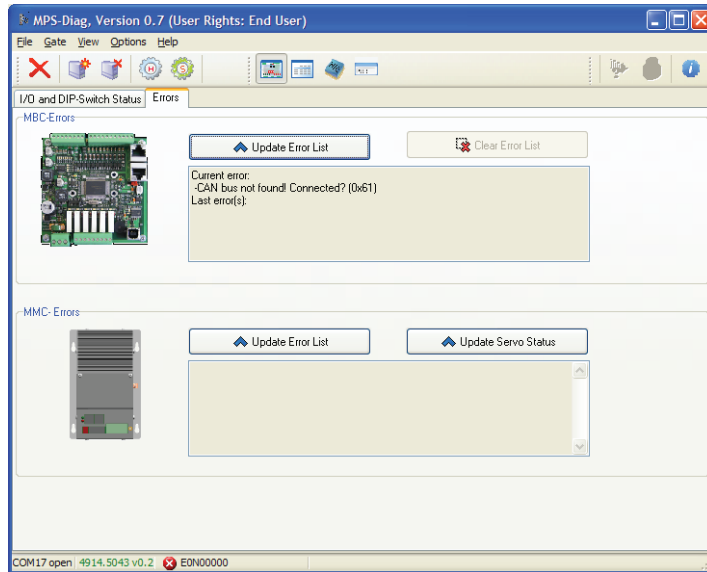

Fig. 56: Reading MBC-111 and MMC-120 errors

Setting motorized gate parameters – "MPS-Diag"

10.8 Status request

Reading the conditions of the in- and outputs right at the MBC-111 is only possible after disassembly after removing the outer tube with the locking element. Therefore, the program MPS-Diag offers the possibility of reading the status of the in- and outputs through the serial interface.



NOTE!

The states of the DIP switches for parametrisation of the CAN bus cannot be read via MPS-Diag. This is only possible directly at the control. Therefore, these settings must be checked before the MPS is assembled!

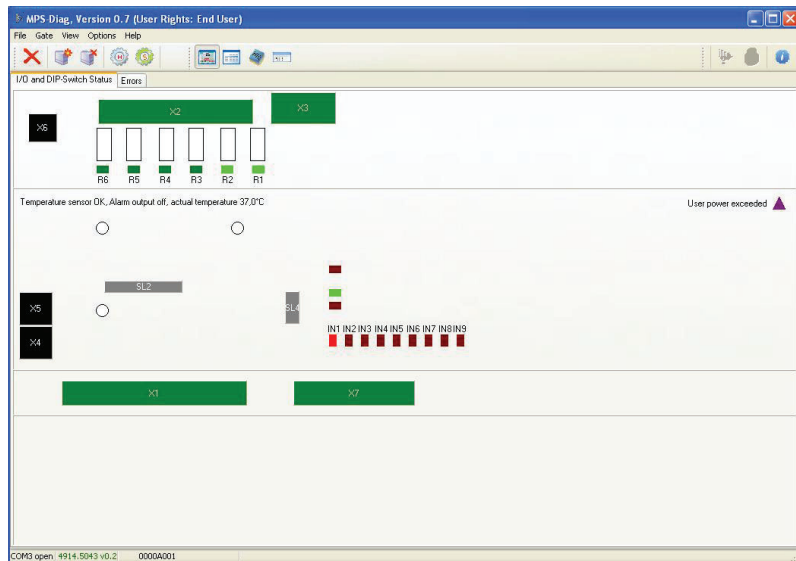



Fig. 57: Reading states of the inputs and outputs and DIP switches

11 Maintenance

11.1 Safety

→ See also safety notes on page 15, chapter 2.6 "Occupational safety and special dangers".

General

⚠ WARNING	
	<p>Danger by inappropriate maintenance! Inappropriate start-up and operation can cause severe or lethal injuries.</p> <ul style="list-style-type: none"> – Only qualified personnel, authorised by the operator and instructed appropriately, may carry out maintenance tasks. – Prior to work, ensure that there is sufficient assembly space. – Pay attention to tidiness and cleanness at the assembly site! Loosely stacked or lying around components and tools are accident sources. – If components have been replaced: Pay attention to correct installation of the spare parts. Reinstall all fastening elements correctly. – Before restarting, ensure that all doors locked properly.

Electric voltage

⚠ DANGER	
	<p>Mortal danger by electric voltage! Touching live parts can be lethal. Damage to the insulation or to individual components can be lethal.</p> <ul style="list-style-type: none"> – Switch off the power supply immediately in case of damage to the insulation and arrange repair. – Only qualified electricians may carry out work on the electrical system. – Switch off power supply and secure against re-activation before performing any work. Test for absence of voltage! – Never bypass or deactivate fuses. – When replacing fuses observe the correct amperage specification. – Keep moisture and dust away from live parts. Moisture or dust may cause a short circuit.

Maintenance

Personal protective equipment

The following must be worn during maintenance work:

- Work clothes
- Protective gloves
- Safety shoes.

11.2 Cleaning

Aggressive cleaning aids and substances

NOTICE	
	<p>Unit damage possible!</p> <p>Aggressive cleaning agents and substances can damage or destroy electrical cables and components.</p> <ul style="list-style-type: none"> – Do not use cleaning agents with aggressive ingredients.

Carrying out cleaning work:

1. Switch off power supply and secure against restarting.
2. Remove soiling appropriately.
 - Clean stainless steel surfaces and power-coated parts regularly with a damp cloth and then dry off carefully.
 - Clean stainless steel surfaces with an appropriate detergent. We recommend 3M stainless steel polish. Apply a thin and even layer of stainless steel detergent and rub dry using a clean and dry disposable cloth.
 - Never use wet cloth.
 - Wash off zinc surfaces using water and a soft cloth. Remove stubborn marks as soon as possible using a standard commercial detergent for zinc (e.g. ROTOL New Formula A2).
3. Absorb lubrication and grease deposits with absorbing materials.
4. After cleaning, check that all previously opened covers have been properly closed and that the functions of any safety equipment fitted have been restored.

11.3 Maintenance schedule

The following describes the maintenance work that is necessary for optimal, trouble-free operation. Maintenance intervals must be observed.

If increased wear of individual components or functional groups is revealed during regular inspections, the operator must reduce the required maintenance intervals on the basis of the actual signs of wear.

In case of queries regarding the maintenance work and intervals: contact the authorised dealer or manufacturer (service address à page 2).

Interval	Maintenance work	To be carried out by
Every 6 months	Visual inspection of the outer motorized gate for damage. Clean the housing and repair paint damage as necessary.	Specialist
	Check the function of the locking element.	Specialist
	Check the attachment of the locking element.	Specialist
	For motorized gate in the wing version: Check the wings for damage	Specialist
	Check function of the residual current operated device	Qualified electrician
Every 12 months	Check electrical cables for damage.	Qualified electrician
	Check all electrical connections for tight fit.	Qualified electrician
	Check signs and labels for legibility.	Specialist
	Check foundation attachment.	Specialist
The electrical tests are to be performed in accordance with the regulations applicable at the installation site.		

Table 8: Maintenance schedule

Malfunctions



12 Malfunctions

12.1 Safety

This chapter describes possible causes of malfunctions and trouble shooting tasks.

Contact the manufacturer in case of malfunctions that cannot be repaired by means of the following information. (For service address, Refer to page 2)

General

 WARNING	
	<p>Danger of injury from inappropriate troubleshooting!</p> <p>Inappropriate troubleshooting can cause severe or lethal injuries.</p> <ul style="list-style-type: none"> – All troubleshooting work must be performed by specialists or electronics specialists. – Prior to work, ensure that there is sufficient assembly space. – Pay attention to tidiness and cleanness at the assembly site! Loosely stacked or lying around components and tools are accident sources. – Only use original spare parts or spare parts approved of by DSI. Procure spare parts from authorised dealers or directly from the manufacturer. Refer to page 2 for address. – If components have been replaced: Pay attention to correct installation of the spare parts. Reinstall all fastening elements correctly. – Before restarting, ensure that all doors locked properly.

Personal protective equipment

The following must be worn during troubleshooting work:

- Work clothes
- Protective gloves
- Safety shoes.

12.2 Error codes on the logic controller MBC-111



NOTE!

Additionally, dispose of the program "MPS Diag" for further diagnostics. Here you can read out the errors via the serial interface. → See page 67, chapter 10.7

Display error codes

The MBC-111 has an LED display for diagnosis purposes. To read the LED display, you have to remove the outer tube with the locking element.

An error code is shown as follows:

- Tens: Flashes slowly
- Ones: Flashes quickly

Examples

The error code "62" is displayed as follows:

- Six slow flashes.
- Two quick flashes.
- After a short break, the error code is repeated.

The error code "02" is displayed as follows:

- Two quick flashes.
- After a short break, the error code is repeated.

There will not be any slow flashing for the tens.

Error code	Fault description	Automatic reset
01	Obstacle detection with runtime monitoring	Yes
02	Emergency entrance is activated	Yes
05	Locking element was pushed into the wrong direction.	Yes
07	Vandalism detection	Yes
12	Voltage supply for external devices at the outputs.	Yes
20	Error MMC control unit	No
21	The MMC control unit's output stage cannot be activated	No
22	Lifeguarding error MMC	No
40	Error during homing	No
41	program code not present	No
50-57	Software fault	No
5C	Temperature too high	Yes
5D	Checksum error EEPROM	No
5E	Checksum error flash	No
5F	Watchdog error	No

Malfunctions

Error code	Fault description	Automatic reset
60	Error when initialising CAN protocol stack	No
61	Error when initialising CAN bus	No
62	CAN servo address fault	No
63	Error download of controller parameters for the MMC-120	No
64	Reserved	No
65	Error I ² C-EEPROM	No
66	Software fault	No
70 to 7F	Error when downloading the MMC-120 firmware	No

Table 9: Error code

Self-resetting errors are displayed for no more than 20 seconds if the error is no longer pending. The error code is shown, however, as long as the error is pending.

The motorized gate is taken out of operation in case of errors that are not self-resetting. The error code is displayed continually until the control is taken into operation again after removal of the error.

13 Spare parts

⚠ WARNING



Risk of injury by incorrect spare parts!

Incorrect or defective spare parts can result in damage, malfunctions or total failure and also impair safety.

- Use only the manufacturer's original spare parts.

Procure spare parts from your dealer or directly from the manufacturer. For the address, see invoice, delivery note or the reverse of these instructions.

Spare part lists can be obtained on request.

Decommissioning and disposal

14 Decommissioning and disposal

A pedestrian barrier that is no longer usable should not be recycled as a complete unit, but disassembled into individual components and recycled according to material types. Non-recyclable materials have to be disposed of in an environmental-friendly manner.

- Decommissioning, disassembly and disposal of the pedestrian barrier may only be carried out by specialised staff.
- Disassemble the pedestrian barrier in reverse order from assembly.
- The pedestrian barrier has to be disposed of in accordance with the respective country-specific regulations.

Appendix

15 Appendix

15.1 Electric circuit diagram

The electric circuit diagram is supplied as a separate document.

Index

A			
Adjusting the end stops	39	Function description.....	45
Assemble MPS column	38	Function settings.....	55
Assembly		G	
Disassemble motorized gate.....	30	General	7
motorized gate.....	28	H	
motorized gate on the foundation	29	Hazard notes	16
Assembly and installation		Homing.....	45
Requirements for assembly	26	I	
B		Instructed people	14
Bracket.....	22, 28	Intended use	12
Bracket version	19	L	
Button		Left motorized gate.....	23
Hold-open time.....	44	Limitation of liability.....	9
Home position	43	Locking element	
C		Bracket version	22, 28
CAN bus addressing.....	42	Wing version	22, 28
Cleaning.....	70	M	
Commissioning		Maintenance	69
Initial commissioning.....	41	Maintenance schedule.....	71
Copyright protection	9	Malfunctions.....	72
Customer service.....	11	Mounting	
D		Locking element.....	38
Decommissioning	76	O	
Design.....	22	Occupational safety	15, 16
Digital inputs	36	Operating conditions	
Dimension.....	19	Technical data.....	21
Disclaimer.....	10	Operating Instructions.....	7
Disposal	76	Operating personnel	
Drilling jig	26	Requirements.....	14
E		Operator's responsibility	13
Electric circuit diagram	78	P	
Electrical connection.....	33	Parameter settings.....	55
Technical data.....	20	Performance data	
Electrical specialists	14	Technical data.....	21
Emergency	48	Personal protective equipment.....	15
Empty conduits	26	Pictogram explanation	8
Environmental protection.....	11	Power supply connection terminals	35
Error codes	73	program MPS-Diag.....	49
F		R	
Firmware download	64	Relay outputs.....	37
Foundation.....	26	Right motorized gate.....	23
Foundation plan.....	27		
Function	23		

Index

S	
Safety	12
Assembly and installation.....	24
Commissioning.....	40
Electrical connection	33
Maintenance.....	69
Malfunctions	72
Scope of delivery	10
Setting	
Hold-open time via the button	44
Home position via the button.....	43
Spare parts	75
Specialised staff.....	14
Specialists	
Requirements	14
motorized gate	
Barrier tube version.....	19
Wing version.....	20
T	
Termination	42
V	
Versions	23
W	
Warning notes	8
Warranty.....	10
Weight	
Technical data	21
Wing	22, 28
Wing version	20



Designed Security, Inc.
1402 Hawthorne Street
Bastrop Texas 78602

Tel.:
800-272-3555/512-321-4426
Fax: 512-321-9181
e-mail: sales@dsigo.com