

# ES500

## Battery Powered Exit Alarm

The ES500 is designed for applications that require an alarmed exit device on secured doors. The alarm, with approximately 100dB, will sound when someone attempts an unauthorized exit. The ES500, with its redesigned shape and smaller size make it the choice for quick and easy installations on emergency exit and restricted doors. Our ES500xMC65 includes a factory installed mortise cylinder. Units without mortise cylinder are also available, as a special order item.

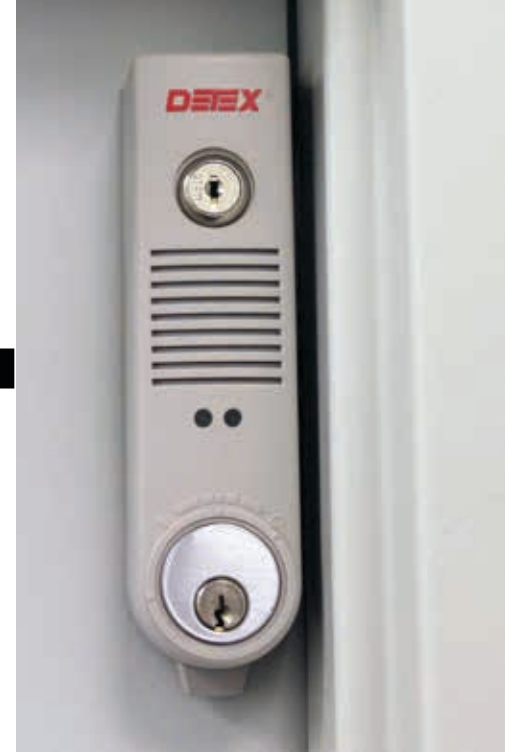

### FEATURES & BENEFITS

- Low cost, self-contained door alarm with piezo horn
- Secure, tamper resistant housing
- Quick, easy installation saves time and money
- Alarm can only be silenced by proper control key
- 9VDC battery operated with Low Battery Alert
- Weatherized unit available (add "W" to part number when ordering)
- UL Listed
- Made in the U.S.A.



Weatherized  
Available

ES500 Series

**DSI**<sup>®</sup>  
DESIGNED SECURITY, INC.  
A Detex Company

Designed Security, Inc.  
302 Detex Drive  
New Braunfels, TX 78130  
800-272-3555  
512-321-4426

www.dsigo.com  
dsi@dsigo.com

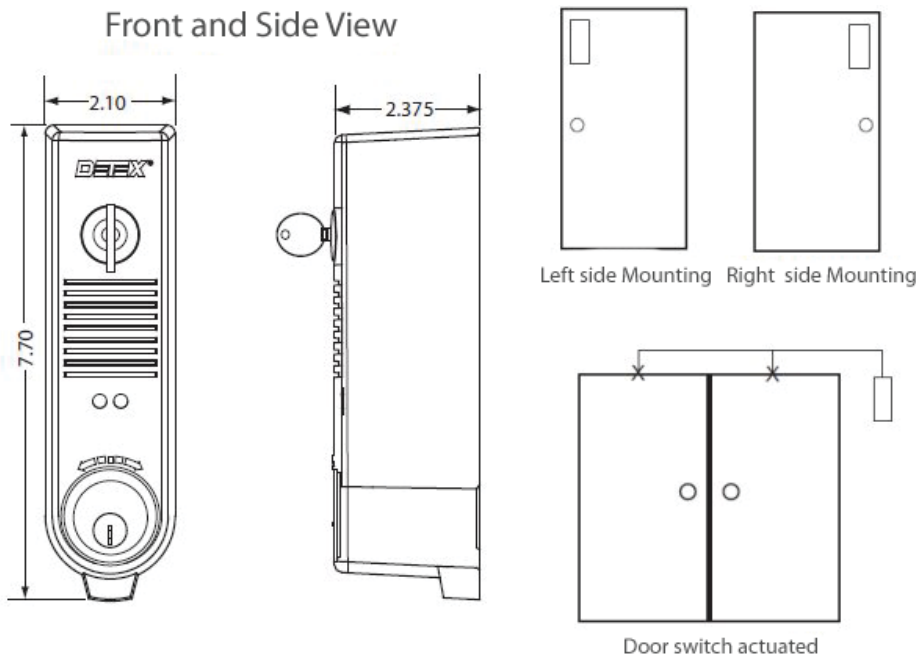

## ELECTRICAL SPECIFICATIONS

Power:	9VDC battery operated, with low battery alert
Local control:	Key switch for reset/bypass
Control input:	Intelligent circuit senses the external magnet location Automatically and sets the correct door hand
Reset time:	Field selectable 2-minute auto rearm
Sound level:	100 dB

## MECHANICAL SPECIFICATIONS

Mounting:	ES500:	Gate, wall, or door mounted
	ES500 xMC65:	Gate, wall, or door mounted
	ES500W:	Gate or door mounted weatherized
	ES500W xMC65:	Gate or door mounted weatherized
Dimensions:	ES500	2.10" w x 7.70" h x 2.375" d
Key switch:	ES500:	Mortise hardware without cylinder (call factory for order information)
	ES500W:	Mortise hardware without cylinder (call factory for order information)
	ES500 xMC65:	Mortise hardware with cylinder
	ES500W xMC65:	Mortise hardware with cylinder
Finish:	Grey	

*Note: Weatherized models do not have an external door switch input.*

## PRODUCT DESCRIPTION

Ideal for fast and easy installations for emergency exits or restricted doors, the ES500 is an optimal choice to reinforce door security. Combining its redesigned smaller size with a powerful 100dB alarm, the ES500 will activate and sound upon an unauthorized exit.

**DSI**<sup>®</sup>  
**DESIGNED SECURITY, INC.**  
 A Detex Company

Designed Security, Inc.  
 302 Detex Drive  
 New Braunfels, TX 78130  
 800-272-3555  
 512-321-4426

[www.dsigo.com](http://www.dsigo.com)  
[dsi@dsigo.com](mailto:dsi@dsigo.com)